

09/28/99

See Sheet 1A For Index of Sheets

STATE OF NORTH CAROLINA
DIVISION OF HIGHWAYS

BURKE COUNTY

LOCATION: SR 1625 (9TH AVE DR NW)

TYPE OF WORK: WIDENING, MILLING, PAVING, PAVEMENT MARKINGS
AND DRAINAGE

STATE	STATE PROJECT REFERENCE NO.	SHEET NO.	TOTAL SHEETS
N.C.	R-5967	1	
STATE PROJ. NO.	F.A. PROJ. NO.	DESCRIPTION	
49086.1.1		P.E.	
49086.2.1		ROW	
49086.3.1	1687001	CONST.	

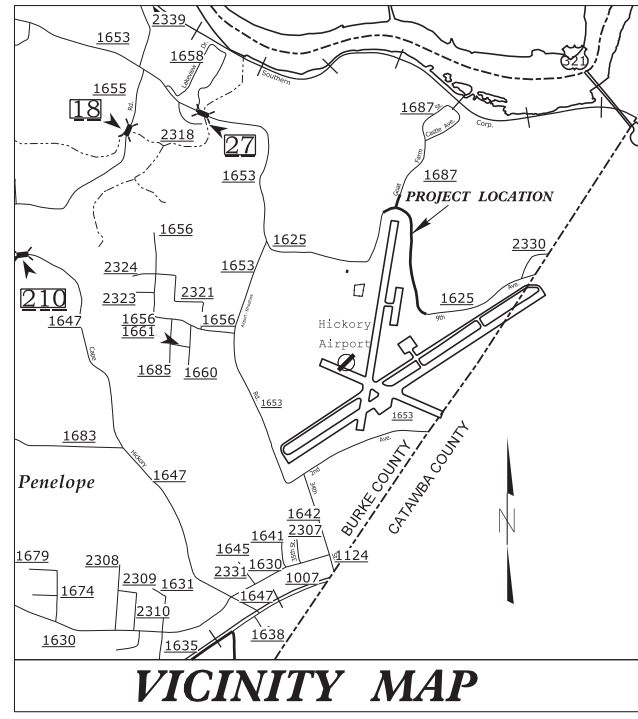

TIP PROJECT: R-5967

CONTRACT: DM00449

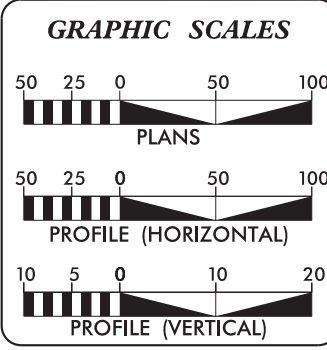
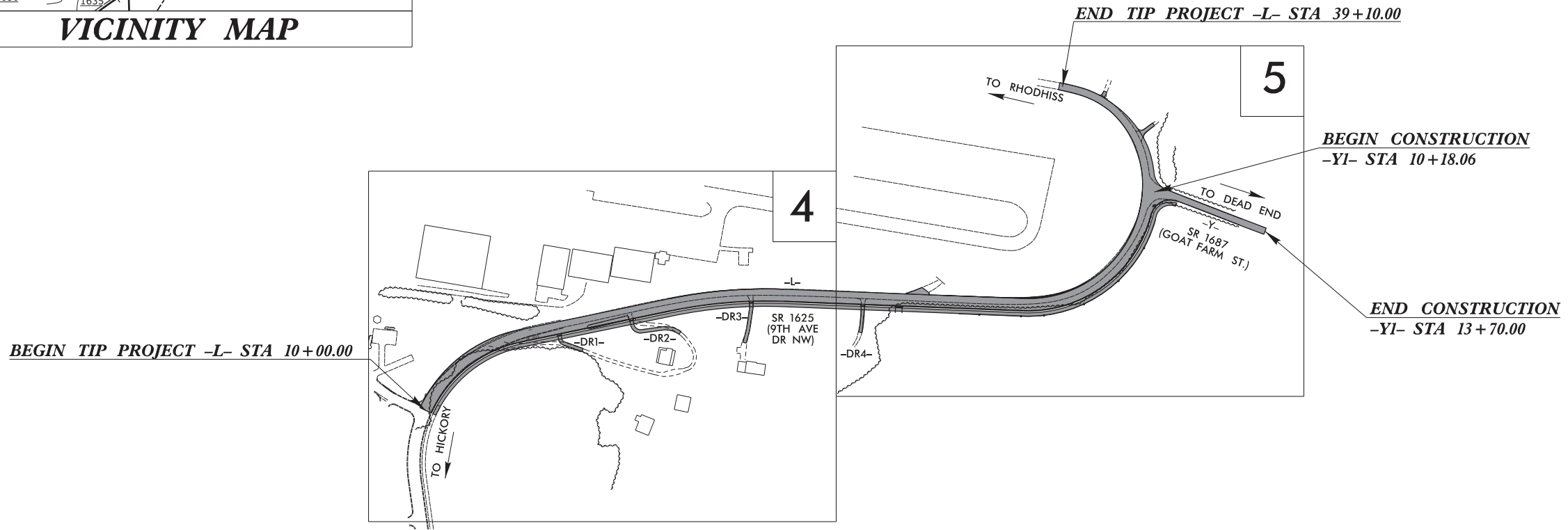

DESIGN DATA

ADT 2040 = 1670

V = 40 MPH

FUNC CLASS = URBAN LOCAL REGIONAL TIER

PROJECT LENGTH

LENGTH OF ROADWAY TIP PROJECT R-5967 = 0.55 MILES

Prepared In the Office of:
DIVISION OF HIGHWAYS
55 Orange St., Asheville NC, 28801

2024 STANDARD SPECIFICATIONS

RIGHT OF WAY DATE: **WILLIAM C. CARVER P.E.**
PROJECT ENGINEER

LETTING DATE: **HAMPTON FLETCHER**
PROJECT DESIGN ENGINEER
JANUARY 3, 2024

HYDRAULICS ENGINEER

DocuSigned by: Jonathan Lyle Moore
SEAL 039745
P.E.

ROADWAY DESIGN ENGINEER

DocuSigned by: William C. Carver
SEAL 041993
ENGINEER
WILLIAM C. CARVER
163525A8519349F 10/17/2023 P.E.

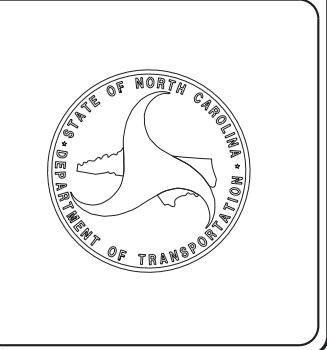

17-OCT-2023 13:38
S:\DCC\Projects\Burke\R-5967\Roadway\Proj\R5967_dcc_tsh.dgn
\$\$\$\$\$SERVNAME\$\$\$\$\$

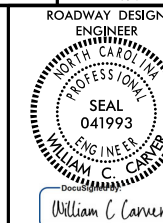

12/04/2023

SHEET NUMBER	INDEX OF SHEETS SHEET
1	TITLE SHEET
1A	INDEX OF SHEETS, GENERAL NOTES, AND STANDARD DRAWINGS
1B	CONVENTIONAL SYMBOLS
2A-1 THRU 2A-4	PAVEMENT SCHEDULE AND TYPICAL SECTIONS
2C-1	SPECIAL DETAILS
2G-1	GEOTECHNICAL DETAILS
3B-1	ROADWAY SUMMARIES
3D-1	DRAINAGE SUMMARIES
4 THRU 9	PLAN AND PROFILE SHEET
RW01 THRU RW05	SURVEY CONTROL SHEETS
TMP-1 THRU TMP-10	TRAFFIC MANAGEMENT PLANS
PMP-1 THRU PMP-3	PAVEMENT MARKING PLANS
EC-1, EC-3 THRU EC-7	EROSION CONTROL PLANS
SIGN-1 THRU SIGN-6	SIGNING PLANS
UC-1 THRU UC-10	UTILITY CONSTRUCTION PLANS
X-1A THRU X-1B	CROSS-SECTION SUMMARY SHEET
X-1 THRU X-17	CROSS-SECTIONS

GENERAL NOTES: 2024 SPECIFICATIONS EFFECTIVE: 01-16-2024 REVISED:

GRADING AND SURFACING OR RESURFACING AND WIDENING:
 THE GRADE LINES SHOWN DENOTE THE FINISHED ELEVATION OF THE PROPOSED SURFACING AT GRADE POINTS SHOWN ON THE TYPICAL SECTIONS. WHERE NO GRADE LINES ARE SHOWN, THE PROFILES SHOWN DENOTE THE TOP ELEVATION OF THE EXISTING PAVEMENT ALONG THE CENTERLINE OF SURVEY ON WHICH THE PROPOSED RESURFACING WILL BE PLACED. GRADE LINES MAY BE ADJUSTED BY THE ENGINEER IN ORDER TO SECURE A PROPER TIE-IN.

CLEARING:
 CLEARING ON THIS PROJECT SHALL BE PERFORMED TO THE LIMITS ESTABLISHED BY METHOD 11.

SUPERELEVATION:
 ALL CURVES ON THIS PROJECT SHALL BE SUPERELEVATED IN ACCORDANCE WITH STD. NO. 224.05 USING THE RATE OF SUPERELEVATION AND RUNOFF SHOWN ON THE PLANS. SUPERELEVATION IS TO BE REVOLVED ABOUT THE GRADE POINTS SHOWN ON THE TYPICAL SECTIONS.

SHOULDER CONSTRUCTION:
 ASPHALT, EARTH, AND CONCRETE SHOULDER CONSTRUCTION ON THE HIGH SIDE OF SUPERELEVATED CURVES SHALL BE IN ACCORDANCE WITH STD. NO. 560.02

SIDE ROADS:
 THE CONTRACTOR WILL BE REQUIRED TO DO ALL NECESSARY WORK TO PROVIDE SUITABLE CONNECTIONS WITH ALL ROADS, STREETS, AND DRIVES ENTERING THIS PROJECT. THIS WORK WILL BE PAID FOR AT THE CONTRACT UNIT PRICE FOR THE PARTICULAR ITEMS INVOLVED.

DRIVEWAYS:
 DRIVEWAYS SHALL BE CONSTRUCTED IN ACCORDANCE WITH STD. 848.03 AT LOCATIONS SHOWN ON PLANS OR AS DIRECTED BY THE ENGINEER.

GUARDRAIL:
 THE GUARDRAIL LOCATIONS SHOWN ON THE PLANS MAY BE ADJUSTED DURING CONSTRUCTION AS DIRECTED BY THE ENGINEER. THE CONTRACTOR SHOULD CONSULT WITH THE ENGINEER PRIOR TO ORDERING GUARDRAIL MATERIAL.

TEMPORARY SHORING:
 SHORING REQUIRED FOR THE MAINTENANCE OF TRAFFIC WILL BE PAID FOR AS "EXTRA WORK" IN ACCORDANCE WITH SECTION 104-7.

UTILITIES:
 UTILITY OWNERS ON THIS PROJECT ARE WATER - CITY OF HICKORY
 INTERNET - CENTRYLINK
 ANY RELOCATION OF EXISTING UTILITIES WILL BE ACCOMPLISHED BY OTHERS, EXCEPT AS SHOWN ON THE PLANS.

RIGHT-OF-WAY MARKERS:
 ALL RIGHT-OF-WAY MARKERS ON THIS PROJECT SHALL BE PLACED BY CONTRACT.

CURB RAMPS
 CURB RAMPS ARE SHOWN ON THE PLANS AT APPROXIMATE LOCATIONS. CONSTRUCT ALL CURB RAMPS ACCORDANCE WITH STD 848.05 and/or 848.06.

2024 ROADWAY ENGLISH STANDARD DRAWINGS EFF. 01-16-2024 REV.

The following Roadway Standards as appear in "Roadway Standard Drawings" Highway Design Branch - N. C. Department of Transportation - Raleigh, N. C., Dated January, 2018 are applicable to this project and by reference hereby are considered a part of these plans:

STD. NO.	TITLE
011510N 2 - EARTHWORK	
200.02	Method of Clearing - Method 11
224.05	Guide for Grading Subgrade - Secondary and Local
224.04	Method of Obtaining Superlevation - Two Lane Pavement
275.06	Method of Grading Sight Distance at Intersections
011510N 3 - PIPE CULVERTS	
300.01	Method of Pipe Installation
310.10	Driveway Pipe Construction
011510N 5 - SUBGRADE, BASES AND SHOULDERS	
560.01	Method of Shoulder Construction - High Side of Superelevated Curve - Method 1
011510N 8 - INCIDENTALS	
806.01	Concrete Right-of-Way Marker
840.03	Frame, Grates and Hood - for Use on Standard Catch Basin
840.16	Drop Inlet Frame and Grates - for use with Std. Dwg 840.14 and 840.15
840.22	Frames and Wide Slot Sag Grates
846.01	Concrete Curb, Gutter and Curb & Gutter
848.01	Concrete Sidewalk
848.02	Driveway Turnout - Radius Type
848.06	Curb Ramp - Proposed Curb & Gutter
862.01	Guardrail Placement
862.02	Guardrail Installation
876.02	Guide for Rip Rap at Pipe Outlets
876.04	Drainage Ditches with Class "B" Rip Rap

8/17/99

04-DEC-2023 14:27 S:\DDC\Projects\Burke\Roadway\Proj\R5967\ddc_tsh.dgn

STATE OF NORTH CAROLINA, DIVISION OF HIGHWAYS CONVENTIONAL PLAN SHEET SYMBOLS

12/2/2016

BOUNDARIES AND PROPERTY:

State Line	-----
County Line	-----
Township Line	-----
City Line	-----
Reservation Line	-----
Property Line	-----
Existing Iron Pin	○ EP
Computed Property Corner	-----
Property Monument	□ EGM
Parcel/Sequence Number	①23
Existing Fence Line	-x-x-x-
Proposed Woven Wire Fence	○
Proposed Chain Link Fence	□
Proposed Barbed Wire Fence	◇
Existing Wetland Boundary	----- WLB
Proposed Wetland Boundary	----- WLB
Existing Endangered Animal Boundary	----- EAB
Existing Endangered Plant Boundary	----- EPB
Existing Historic Property Boundary	----- HPB
Known Contamination Area: Soil	☠-S-☠
Potential Contamination Area: Soil	☠-S-☠
Known Contamination Area: Water	☠-W-☠
Potential Contamination Area: Water	☠-W-☠
Contaminated Site: Known or Potential	☠ ?

BUILDINGS AND OTHER CULTURE:

Gas Pump Vent or U/G Tank Cap	○
Sign	○ S
Well	○ W
Small Mine	✕
Foundation	□
Area Outline	□
Cemetery	⊕
Building	□
School	□
Church	⊕
Dam	▬

HYDROLOGY:

Stream or Body of Water	-----
Hydro, Pool or Reservoir	-----
Jurisdictional Stream	----- JS
Buffer Zone 1	----- BZ 1
Buffer Zone 2	----- BZ 2
Flow Arrow	←
Disappearing Stream	-----
Spring	○
Wetland	-----
Proposed Lateral, Tail, Head Ditch	-----
False Sump	-----

RAILROADS:

Standard Gauge	-----
RR Signal Milepost	○ MILEPOST 35
Switch	□ SWITCH
RR Abandoned	-----
RR Dismantled	-----

RIGHT OF WAY & PROJECT CONTROL:

Secondary Horiz and Vert Control Point	◆
Primary Horiz Control Point	⬢
Primary Horiz and Vert Control Point	⬢
Exist Permanent Easement Pin and Cap	◆
New Permanent Easement Pin and Cap	◆
Vertical Benchmark	⊕
Existing Right of Way Marker	△
Existing Right of Way Line	-----
New Right of Way Line	-----
New Right of Way Line with Pin and Cap	-----
New Right of Way Line with Concrete or Granite RW Marker	-----
New Control of Access Line with Concrete C/A Marker	-----
Existing Control of Access	-----
New Control of Access	-----
Existing Easement Line	----- E
New Temporary Construction Easement	----- E
New Temporary Drainage Easement	----- TDE
New Permanent Drainage Easement	----- PDE
New Permanent Drainage / Utility Easement	----- DUE
New Permanent Utility Easement	----- PUE
New Temporary Utility Easement	----- TUE
New Aerial Utility Easement	----- AUE

ROADS AND RELATED FEATURES:

Existing Edge of Pavement	-----
Existing Curb	-----
Proposed Slope Stakes Cut	----- C
Proposed Slope Stakes Fill	----- F
Proposed Curb Ramp	----- CR
Existing Metal Guardrail	-----
Proposed Guardrail	-----
Existing Cable Guiderail	-----
Proposed Cable Guiderail	-----
Equality Symbol	⊕
Pavement Removal	-----

VEGETATION:

Single Tree	☼
Single Shrub	☼

Note: Not to Scale *S.U.E. = Subsurface Utility Engineering

Hedge	-----
Woods Line	-----
Orchard	-----
Vineyard	-----

EXISTING STRUCTURES:

MAJOR:	
Bridge, Tunnel or Box Culvert	----- CONC
Bridge Wing Wall, Head Wall and End Wall	----- CONC WW
MINOR:	
Head and End Wall	----- CONC HW
Pipe Culvert	-----
Footbridge	-----
Drainage Box: Catch Basin, DI or JB	□ CB
Paved Ditch Gutter	-----
Storm Sewer Manhole	⊕
Storm Sewer	----- S

UTILITIES:

POWER:	
Existing Power Pole	●
Proposed Power Pole	○
Existing Joint Use Pole	●
Proposed Joint Use Pole	○
Power Manhole	⊕
Power Line Tower	⊗
Power Transformer	⊗
U/G Power Cable Hand Hole	-----
H-Frame Pole	-----
U/G Power Line LOS B (S.U.E.*)	----- P
U/G Power Line LOS C (S.U.E.*)	----- P
U/G Power Line LOS D (S.U.E.*)	----- P

TELEPHONE:

Existing Telephone Pole	●
Proposed Telephone Pole	○
Telephone Manhole	⊕
Telephone Pedestal	⊕
Telephone Cell Tower	⊕
U/G Telephone Cable Hand Hole	-----
U/G Telephone Cable LOS B (S.U.E.*)	----- T
U/G Telephone Cable LOS C (S.U.E.*)	----- T
U/G Telephone Cable LOS D (S.U.E.*)	----- T
U/G Telephone Conduit LOS B (S.U.E.*)	----- TC
U/G Telephone Conduit LOS C (S.U.E.*)	----- TC
U/G Telephone Conduit LOS D (S.U.E.*)	----- TC
U/G Fiber Optics Cable LOS B (S.U.E.*)	----- T FO
U/G Fiber Optics Cable LOS C (S.U.E.*)	----- T FO
U/G Fiber Optics Cable LOS D (S.U.E.*)	----- T FO

WATER:

Water Manhole	⊕
Water Meter	○
Water Valve	⊗
Water Hydrant	⊕
U/G Water Line LOS B (S.U.E.*)	-----
U/G Water Line LOS C (S.U.E.*)	-----
U/G Water Line LOS D (S.U.E.*)	-----
Above Ground Water Line	----- A/G Water

TV:

TV Pedestal	⊕
TV Tower	⊗
U/G TV Cable Hand Hole	-----
U/G TV Cable LOS B (S.U.E.*)	----- TV
U/G TV Cable LOS C (S.U.E.*)	----- TV
U/G TV Cable LOS D (S.U.E.*)	----- TV
U/G Fiber Optic Cable LOS B (S.U.E.*)	----- TV FO
U/G Fiber Optic Cable LOS C (S.U.E.*)	----- TV FO
U/G Fiber Optic Cable LOS D (S.U.E.*)	----- TV FO

GAS:

Gas Valve	◇
Gas Meter	⊕
U/G Gas Line LOS B (S.U.E.*)	----- G
U/G Gas Line LOS C (S.U.E.*)	----- G
U/G Gas Line LOS D (S.U.E.*)	----- G
Above Ground Gas Line	----- A/G Gas

SANITARY SEWER:

Sanitary Sewer Manhole	⊕
Sanitary Sewer Cleanout	⊕
U/G Sanitary Sewer Line	----- SS
Above Ground Sanitary Sewer	----- A/G Sanitary Sewer
SS Forced Main Line LOS B (S.U.E.*)	----- FSS
SS Forced Main Line LOS C (S.U.E.*)	----- FSS
SS Forced Main Line LOS D (S.U.E.*)	----- FSS

MISCELLANEOUS:

Utility Pole	●
Utility Pole with Base	□
Utility Located Object	○
Utility Traffic Signal Box	⊕
Utility Unknown U/G Line LOS B (S.U.E.*)	-----
U/G Tank; Water, Gas, Oil	-----
Underground Storage Tank, Approx. Loc.	⊕
A/G Tank; Water, Gas, Oil	-----
Geoenvironmental Boring	⊕
U/G Test Hole LOS A (S.U.E.*)	⊕
Abandoned According to Utility Records	AATUR
End of Information	E.O.I.

* 7' WITH GUARDRAIL

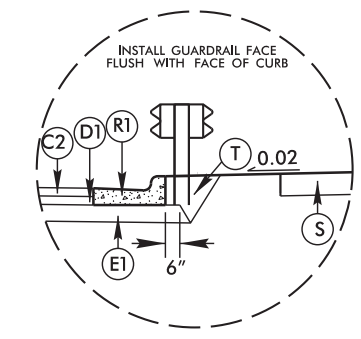
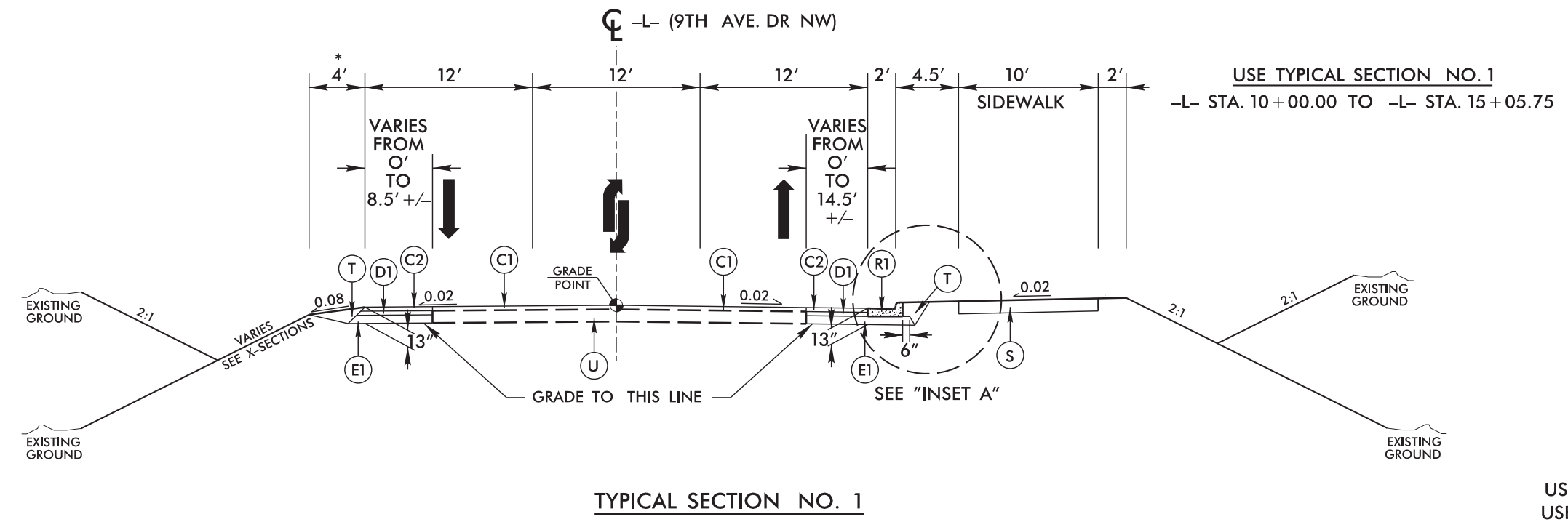

* 7' WITH GUARDRAIL

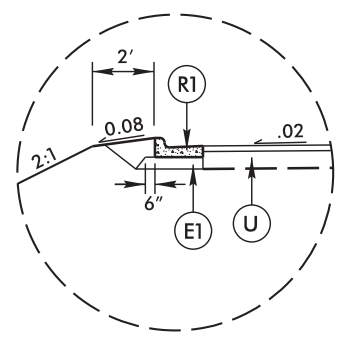
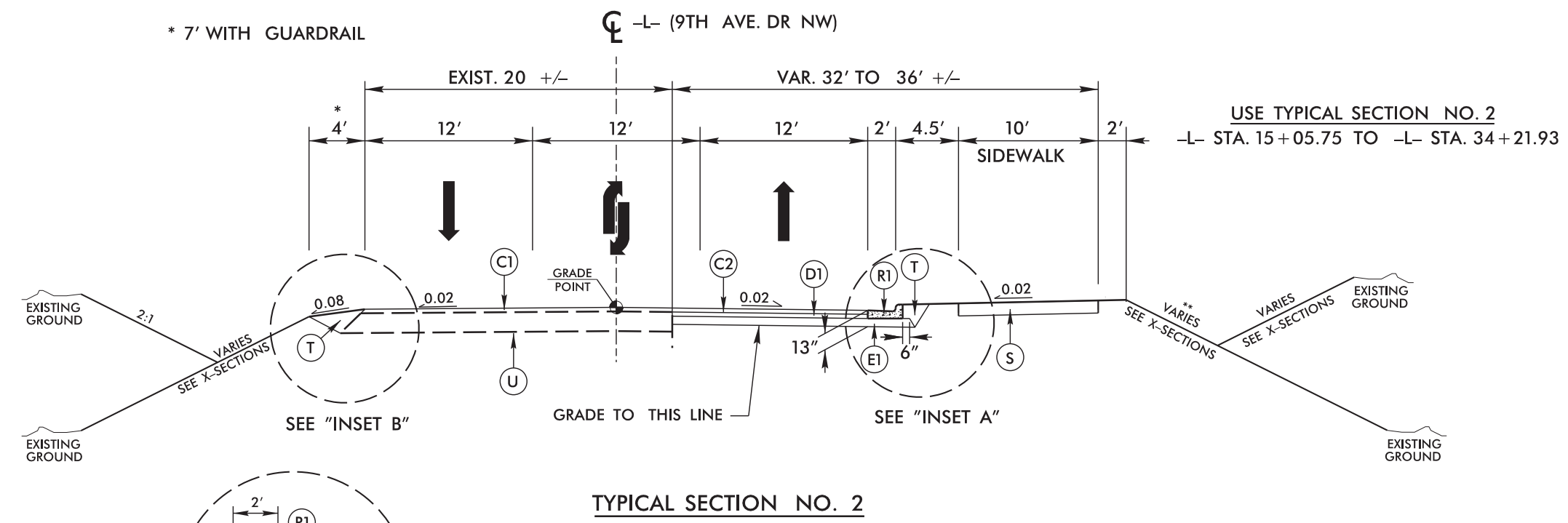

PAVEMENT SCHEDULE	
C1	PROP. APPROX. 1 1/2" ASPHALT CONCRETE SURFACE COURSE, TYPE S9.5C, AT AN AVERAGE RATE OF 168 LBS. PER SQ. YD.
C2	PROP. APPROX. 3" ASPHALT CONCRETE SURFACE COURSE, TYPE S9.5C, AT AN AVERAGE RATE OF 168 LBS. PER SQ. YD. IN EACH OF TWO LAYERS.
C3	PROP. VAR. DEPTH ASPHALT CONCRETE SURFACE COURSE, TYPE S9.5C, AT AN AVERAGE RATE OF 112 LBS. PER SQ. YD. PER 1" DEPTH. TO BE PLACED IN LAYERS NOT TO EXCEED 2" IN DEPTH.
D1	PROP. APPROX. 4" ASPHALT CONCRETE INTERMEDIATE COURSE, TYPE 119.0C, AT AN AVERAGE RATE OF 456 LBS. PER SQ. YD.
D2	PROP. VAR. DEPTH ASPHALT CONCRETE INTERMEDIATE COURSE, TYPE 119.0C, AT AN AVERAGE RATE OF 114 LBS. PER SQ. YD. PER 1" DEPTH, TO BE PLACED IN LAYERS NOT LESS THAN 2 1/2" IN DEPTH OR GREATER THAN 4" IN DEPTH.
E1	PROP. APPROX. 6" ASPHALT CONCRETE BASE COURSE, TYPE B25.0C, AT AN AVERAGE RATE OF 342 LBS. PER SQ. YD. IN EACH OF TWO LAYERS
E2	PROP. VAR. DEPTH ASPHALT CONCRETE BASE COURSE, TYPE B25.0C, AT AN AVERAGE RATE OF 114 LBS. PER SQ. YD. PER 1" DEPTH, TO BE PLACED IN LAYERS NOT LESS THAN 3" IN DEPTH OR GREATER THAN 5 1/2" IN DEPTH.
J1	PROP. 8" AGGREGATE BASE COURSE.
R1	2'-6" CONCRETE CURB AND GUTTER.
R3	6" CONCRETE DRIVEWAY.
S	4" CONCRETE SIDEWALK.
T	EARTH MATERIAL.
U	EXISTING PAVEMENT.
W	WEDGING EXISTING PAVEMENT

**NOTE: USE 1.5:1 SLOPE BETWEEN STA. 31+00 RT TO 33+00 RT

PAVEMENT EDGE SLOPES ARE 1:1 UNLESS SHOWN OTHERWISE.

6/2/99
 21-JUL-2023 14:26
 S:\DCC\Projects\Burke\R-5967\Roadway\Proj\AR5967_ddc_ttypnew.dgn

* 7' WITH GUARDRAIL

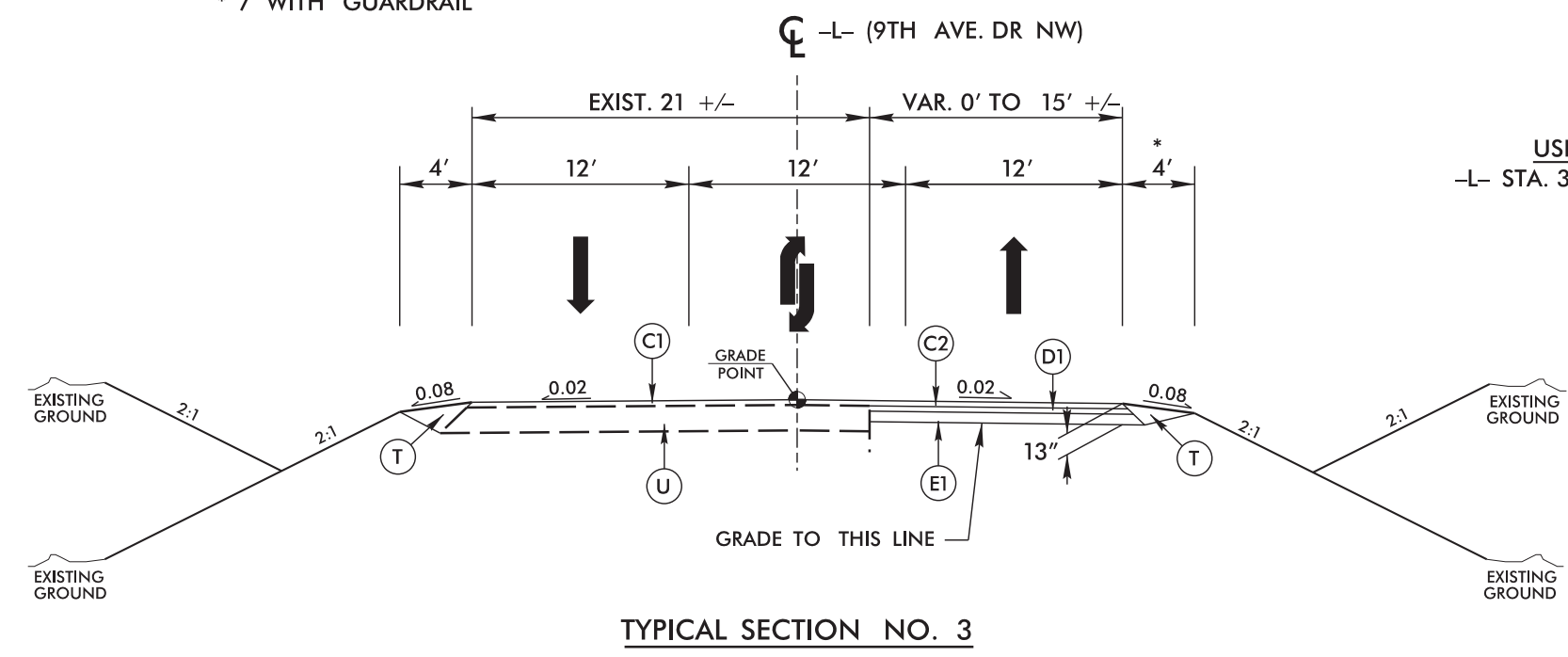

USE TYPICAL SECTION NO. 3
-L- STA. 34+21.93 TO -L- STA. 35+86.00

TYPICAL SECTION NO. 3

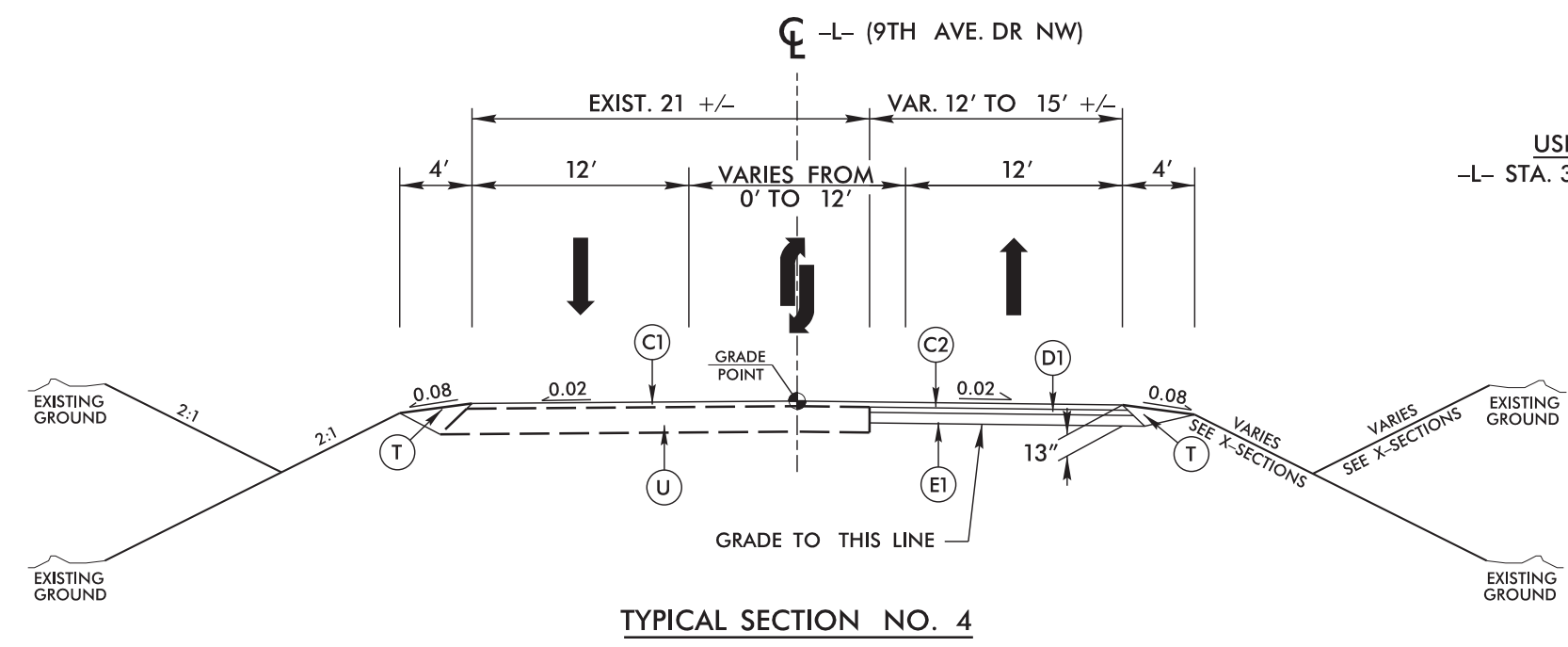

USE TYPICAL SECTION NO. 4
-L- STA. 35+86.00 TO -L- STA. 37+14.41

TYPICAL SECTION NO. 4

PAVEMENT SCHEDULE	
C1	PROP. APPROX. 1 1/2" ASPHALT CONCRETE SURFACE COURSE, TYPE S9.5C, AT AN AVERAGE RATE OF 168 LBS. PER SQ. YD.
C2	PROP. APPROX. 3" ASPHALT CONCRETE SURFACE COURSE, TYPE S9.5C, AT AN AVERAGE RATE OF 168 LBS. PER SQ. YD. IN EACH OF TWO LAYERS.
C3	PROP. VAR. DEPTH ASPHALT CONCRETE SURFACE COURSE, TYPE S9.5C, AT AN AVERAGE RATE OF 112 LBS. PER SQ. YD. PER 1" DEPTH. TO BE PLACED IN LAYERS NOT TO EXCEED 2" IN DEPTH.
D1	PROP. APPROX. 4" ASPHALT CONCRETE INTERMEDIATE COURSE, TYPE I19.0C, AT AN AVERAGE RATE OF 456 LBS. PER SQ. YD.
D2	PROP. VAR. DEPTH ASPHALT CONCRETE INTERMEDIATE COURSE, TYPE I19.0C, AT AN AVERAGE RATE OF 114 LBS. PER SQ. YD. PER 1" DEPTH, TO BE PLACED IN LAYERS NOT LESS THAN 2 1/2" IN DEPTH OR GREATER THAN 4" IN DEPTH.
E1	PROP. APPROX. 6" ASPHALT CONCRETE BASE COURSE, TYPE B25.0C, AT AN AVERAGE RATE OF 342 LBS. PER SQ. YD. IN EACH OF TWO LAYERS
E2	PROP. VAR. DEPTH ASPHALT CONCRETE BASE COURSE, TYPE B25.0C, AT AN AVERAGE RATE OF 114 LBS. PER SQ. YD. PER 1" DEPTH. TO BE PLACED IN LAYERS NOT LESS THAN 3" IN DEPTH OR GREATER THAN 5 1/2" IN DEPTH.
J1	PROP. 6" AGGREGATE BASE COURSE.
R1	2'-6" CONCRETE CURB AND GUTTER.
R3	6" CONCRETE DRIVEWAY.
S	4" CONCRETE SIDEWALK.
T	EARTH MATERIAL.
U	EXISTING PAVEMENT.
W	WEDGING EXISTING PAVEMENT

PAVEMENT EDGE SLOPES ARE 1:1 UNLESS SHOWN OTHERWISE.

6/2/99
 21-JUL-2023 14:27
 S:\DDC\Projects\Burke\R-5967\Roadway\Proj\AR5967_ddc_typnew.dgn

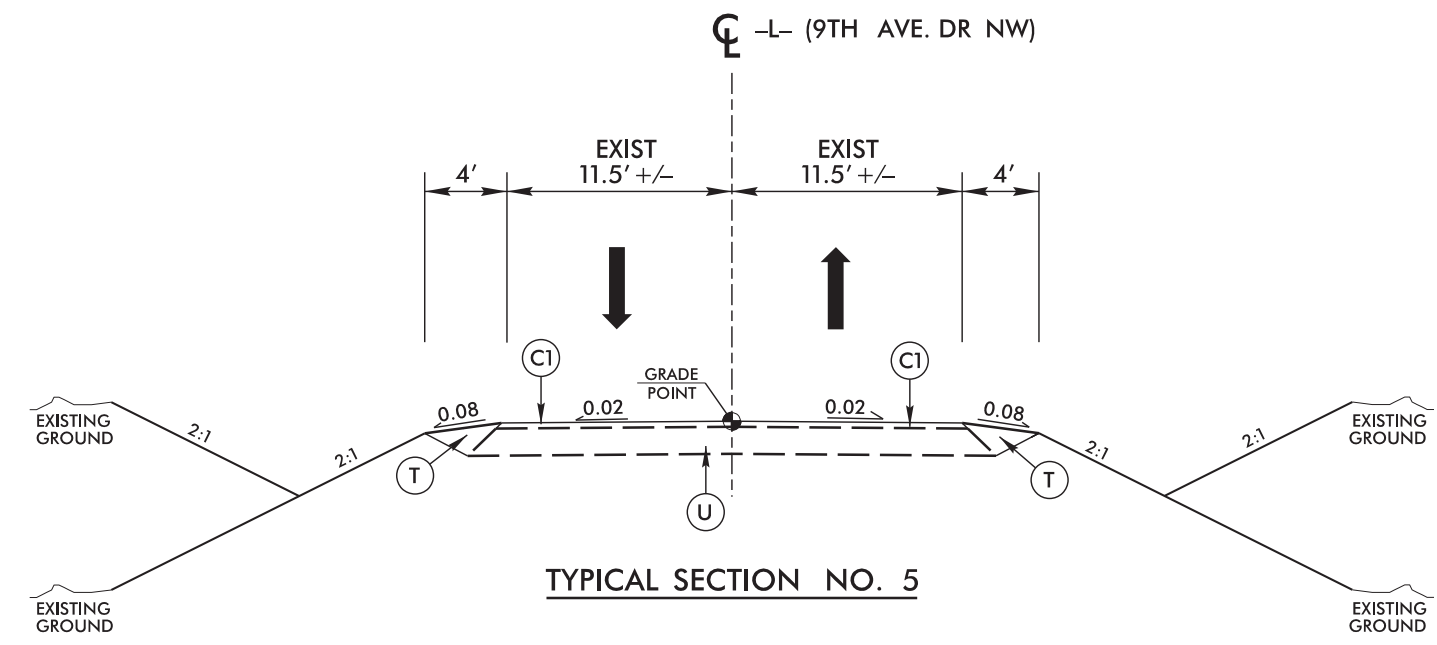

TYPICAL SECTION NO. 5

USE TYPICAL SECTION NO. 5
-L- STA. 37+14.41 TO -L- STA. 39+10

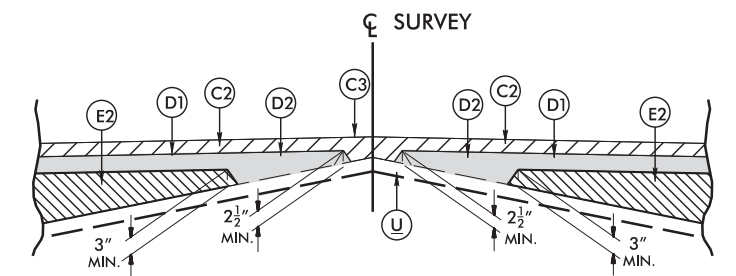

Detail Showing Method of Wedging

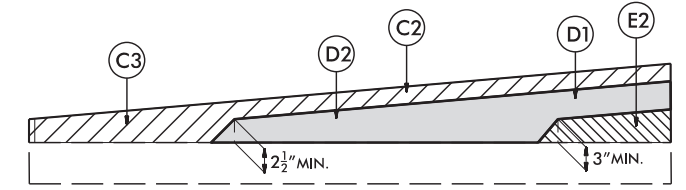

Wedging Detail For Resurfacing

***** 5' WITH GUARDRAIL**

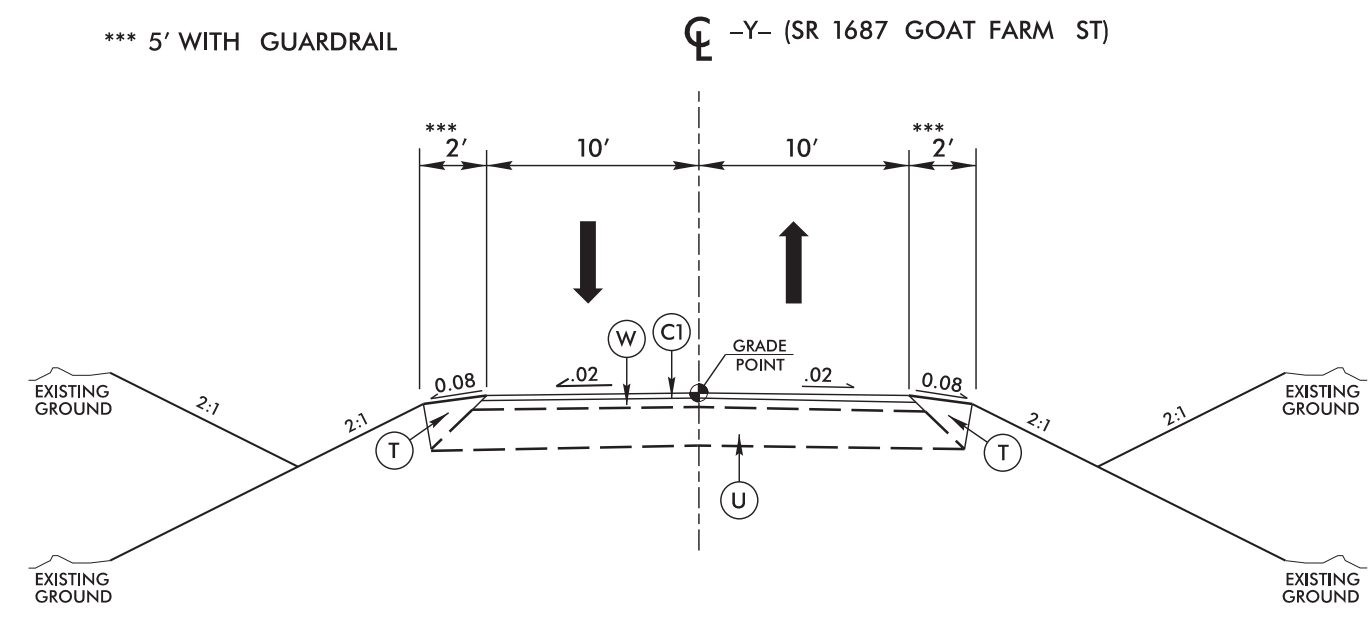

TYPICAL SECTION NO. 6

USE TYPICAL SECTION NO. 6
-Y- STA. 10+17.69 TO -Y- STA. 13+70.00

PAVEMENT SCHEDULE	
C1	PROP. APPROX. 1 1/2" ASPHALT CONCRETE SURFACE COURSE, TYPE S9.5C, AT AN AVERAGE RATE OF 168 LBS. PER SQ. YD.
C2	PROP. APPROX. 3" ASPHALT CONCRETE SURFACE COURSE, TYPE S9.5C, AT AN AVERAGE RATE OF 168 LBS. PER SQ. YD. IN EACH OF TWO LAYERS.
C3	PROP. VAR. DEPTH ASPHALT CONCRETE SURFACE COURSE, TYPE S9.5C, AT AN AVERAGE RATE OF 112 LBS. PER SQ. YD. PER 1" DEPTH. TO BE PLACED IN LAYERS NOT TO EXCEED 2" IN DEPTH.
D1	PROP. APPROX. 4" ASPHALT CONCRETE INTERMEDIATE COURSE, TYPE I19.0C, AT AN AVERAGE RATE OF 456 LBS. PER SQ. YD.
D2	PROP. VAR. DEPTH ASPHALT CONCRETE INTERMEDIATE COURSE, TYPE I19.0C, AT AN AVERAGE RATE OF 114 LBS. PER SQ. YD. PER 1" DEPTH. TO BE PLACED IN LAYERS NOT LESS THAN 2 1/2" IN DEPTH OR GREATER THAN 4" IN DEPTH.
E1	PROP. APPROX. 6" ASPHALT CONCRETE BASE COURSE, TYPE B25.0C, AT AN AVERAGE RATE OF 342 LBS. PER SQ. YD. IN EACH OF TWO LAYERS.
E2	PROP. VAR. DEPTH ASPHALT CONCRETE BASE COURSE, TYPE B25.0C, AT AN AVERAGE RATE OF 114 LBS. PER SQ. YD. PER 1" DEPTH. TO BE PLACED IN LAYERS NOT LESS THAN 3" IN DEPTH OR GREATER THAN 5 1/2" IN DEPTH.
J1	PROP. 8" AGGREGATE BASE COURSE.
R1	2'-6" CONCRETE CURB AND GUTTER.
R3	6" CONCRETE DRIVEWAY.
S	4" CONCRETE SIDEWALK.
T	EARTH MATERIAL.
U	EXISTING PAVEMENT.
W	WEDGING EXISTING PAVEMENT

PAVEMENT EDGE SLOPES ARE 1:1 UNLESS SHOWN OTHERWISE.

6/2/99
 21-JUL-2023 14:29
 S:\DCC\Projects\Burke\R-5967\Roadway\Proj\AR5967_ddc_typnew.dgn

6/2/99

PROJECT REFERENCE NO. R-5967	SHEET NO. 2A-4
ROADWAY DESIGN ENGINEER WILLIAM C. CARVER 183525A8519349F SEAL 041993 NORTH CAROLINA PROFESSIONAL ENGINEER	PAVEMENT DESIGN ENGINEER
DocuSigned by: <i>William C. Carver</i>	08/15/2023
DOCUMENT NOT CONSIDERED FINAL UNLESS ALL SIGNATURES COMPLETED	

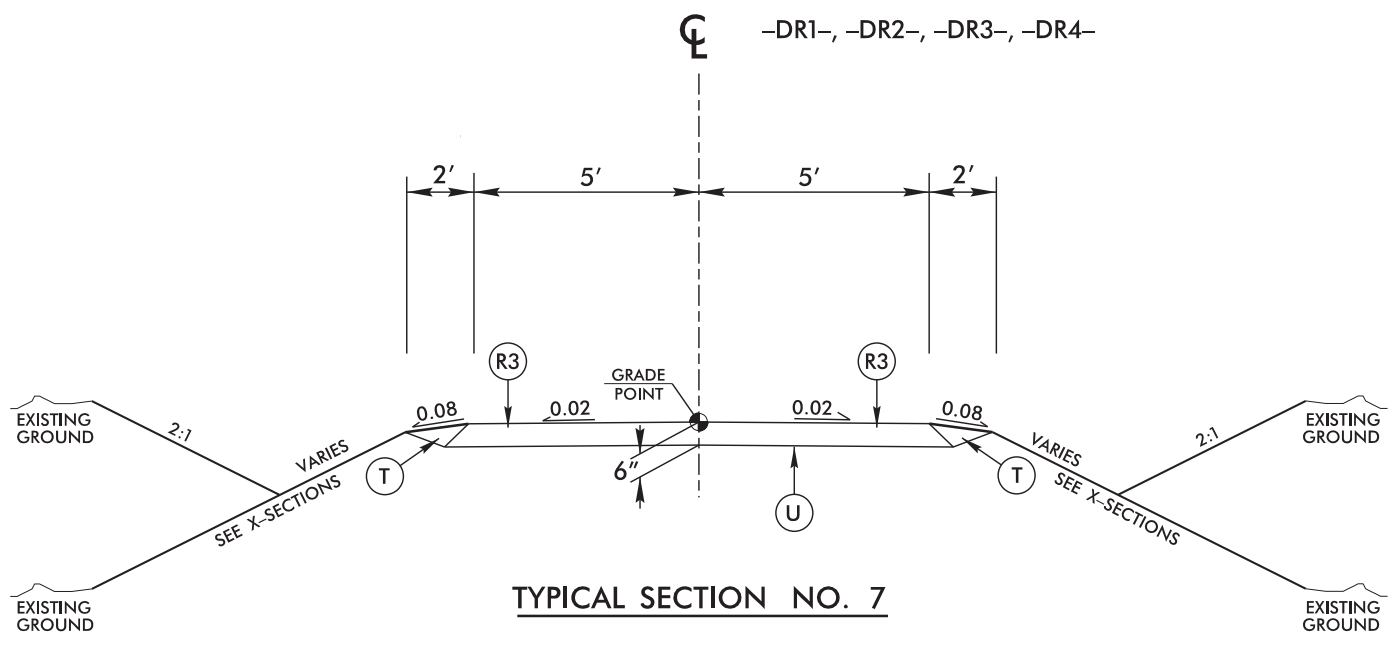

USE TYPICAL SECTION NO. 7
 -DR1- STA. 10+18.00 TO -DR1- STA. 10+40.07
 -DR2- STA. 10+18.00 TO -DR2- STA. 10+40.02
 -DR3- STA. 10+18.00 TO -DR3- STA. 10+40.02
 -DR4- STA. 10+18.00 TO -DR4- STA. 11+02.39

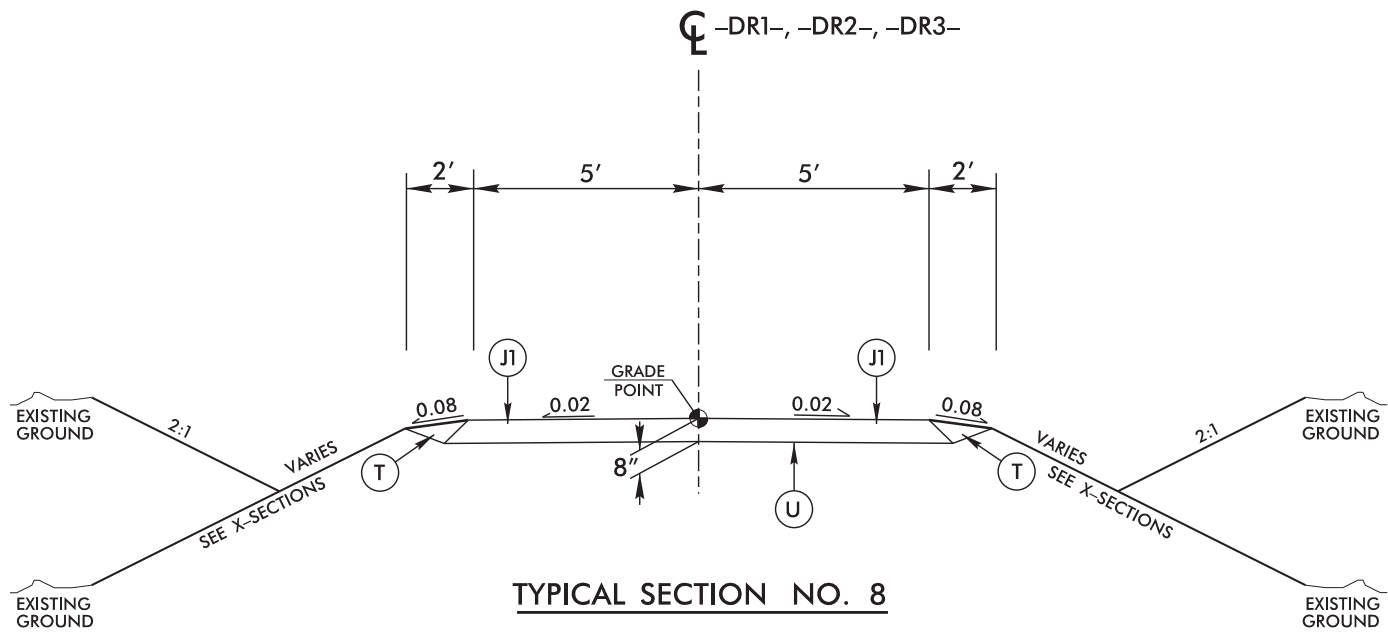

USE TYPICAL SECTION NO. 8
 -DR1- STA. 10+40.07 TO -DR1- STA. 11+11.11
 -DR2- STA. 10+40.02 TO -DR2- STA. 11+91.69
 -DR3- STA. 10+40.02 TO -DR3- STA. 11+44.72

PAVEMENT SCHEDULE	
C1	PROP. APPROX. 1 1/2" ASPHALT CONCRETE SURFACE COURSE, TYPE S9.5C, AT AN AVERAGE RATE OF 168 LBS. PER SQ. YD.
C2	PROP. APPROX. 3" ASPHALT CONCRETE SURFACE COURSE, TYPE S9.5C, AT AN AVERAGE RATE OF 168 LBS. PER SQ. YD. IN EACH OF TWO LAYERS.
C3	PROP. VAR. DEPTH ASPHALT CONCRETE SURFACE COURSE, TYPE S9.5C, AT AN AVERAGE RATE OF 112 LBS. PER SQ. YD. PER 1" DEPTH. TO BE PLACED IN LAYERS NOT TO EXCEED 2" IN DEPTH.
D1	PROP. APPROX. 4" ASPHALT CONCRETE INTERMEDIATE COURSE, TYPE I19.0C, AT AN AVERAGE RATE OF 456 LBS. PER SQ. YD.
D2	PROP. VAR. DEPTH ASPHALT CONCRETE INTERMEDIATE COURSE, TYPE I19.0C, AT AN AVERAGE RATE OF 114 LBS. PER SQ. YD. PER 1" DEPTH. TO BE PLACED IN LAYERS NOT LESS THAN 2 1/2" IN DEPTH OR GREATER THAN 4" IN DEPTH.
E1	PROP. APPROX. 6" ASPHALT CONCRETE BASE COURSE, TYPE B25.0C, AT AN AVERAGE RATE OF 342 LBS. PER SQ. YD. IN EACH OF TWO LAYERS
E2	PROP. VAR. DEPTH ASPHALT CONCRETE BASE COURSE, TYPE B25.0C, AT AN AVERAGE RATE OF 114 LBS. PER SQ. YD. PER 1" DEPTH. TO BE PLACED IN LAYERS NOT LESS THAN 3" IN DEPTH OR GREATER THAN 5 1/2" IN DEPTH.
J1	PROP. 8" AGGREGATE BASE COURSE.
R1	2'-6" CONCRETE CURB AND GUTTER.
R3	6" CONCRETE DRIVEWAY.
S	4" CONCRETE SIDEWALK.
T	EARTH MATERIAL.
U	EXISTING PAVEMENT.
W	WEDGING EXISTING PAVEMENT

PAVEMENT EDGE SLOPES ARE 1:1 UNLESS SHOWN OTHERWISE.

21-JUL-2023 14:30
 S:\DCC\Projects\Burke\R-5967\Roadway\Proj\AR5967_ddc_ttypnew.dgn

TIMBER RAIL FENCE DETAIL

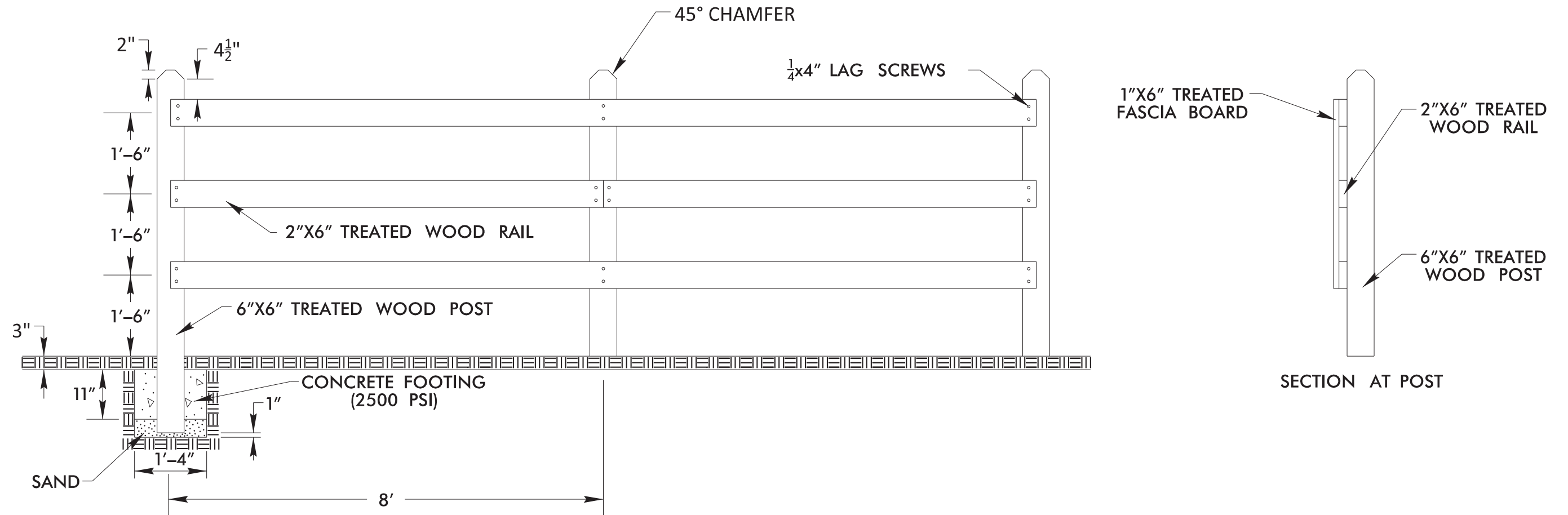

TIMBER RAIL FENCE TO BE CONSTRUCTED AT THE FOLLOWING LOCATIONS IN CONJUNCTION WITH THE TYPICAL SECTIONS AND AS DIRECTED BY THE ENGINEER.

-L- STA. 27+00 TO STA. 33+75.00 RT (1' FROM TRAIL)

GEOTECHNICAL ENGINEER

ENGINEER



DocuSigned by: Jody Kujawa 11/18/2021

DOCUMENT NOT CONSIDERED FINAL UNLESS ALL SIGNATURES COMPLETED

QUANTITY SUMMARY			
STATION FROM	STATION TO	LINE	CLASS VII ROCK CUBIC YARDS
32+00	34+00	RT -L-	1,500 YDS ³
		TOTAL	3,000 TONS
32+00	34+00	RT -L-	TYPE IV GEOTEXTILE
		TOTAL	250 YDS ²

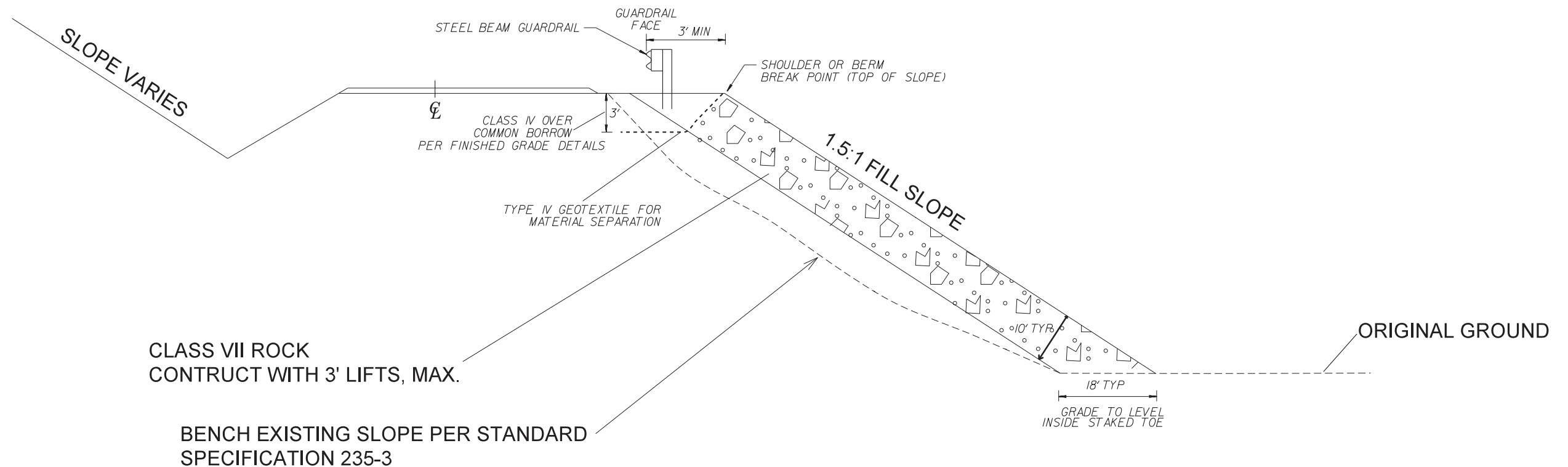

NOTES:

- 1) USE CLASS VII ROCK TO CONSTRUCT EXPANDED FILLS WHICH ARE 1.5:1 (H:V) AS SHOWN ON PLANS
- 2) CONSTRUCT WITH 3' LIFTS, MAX



NORTH CAROLINA DEPARTMENT OF TRANSPORTATION DIVISION OF HIGHWAYS

GEOTECHNICAL ENGINEERING UNIT

ROCK EMBANKMENT DETAIL

TYPICAL FOR ALL FILL SLOPES 1.5:1 (H:V) AS SHOWN ON PLANS

-L-		-DRI-		-DR2-		-DR3-	
PI Sta 12+00.72	PI Sta 20+05.37	PI Sta 10+43.85	PI Sta 10+59.14	PI Sta 11+73.06	PI Sta 10+37.66	PI Sta 11+04.48	
$\Delta = 53^{\circ}17'39.2"$ (RT)	$\Delta = 13^{\circ}57'06.9"$ (RT)	$\Delta = 58^{\circ}26'58.2"$ (LT)	$\Delta = 86^{\circ}04'00.3"$ (LT)	$\Delta = 54^{\circ}02'32.4"$ (RT)	$\Delta = 10^{\circ}15'24.4"$ (RT)	$\Delta = 6^{\circ}31'13.3"$ (RT)	
D = 14'19" 26.2"	D = 4'05" 33.2"	D = 38'58" 18.7"	D = 232'09" 03.4"	D = 79'27" 42.8"	D = 114'35" 29.6"	D = 28'38" 52.4"	
L = 372.06'	L = 340.91'	L = 15.30'	L = 37.07'	L = 68.01'	L = 8.95'	L = 22.76'	
T = 200.72'	T = 171.30'	T = 8.39'	T = 23.04'	T = 36.77'	T = 4.49'	T = 11.39'	
R = 400.00'	R = 1400.00'	R = 15.00'	R = 24.68'	R = 72.10'	R = 50.00'	R = 200.00'	
DS = 45	DS = 45						
SE = 0.04	SE = 0.04						

PROJECT REFERENCE NO. R-5967	SHEET NO. 4
ROADWAY DESIGN ENGINEER SEAL 041993 WILLIAM C. CARVER	HYDRAULICS ENGINEER SEAL 039745 CDDGBERCTEE42
Designed by: <i>William C. Carver</i> 08/15/2023	
DOCUMENT NOT CONSIDERED FINAL UNLESS ALL SIGNATURES COMPLETED	

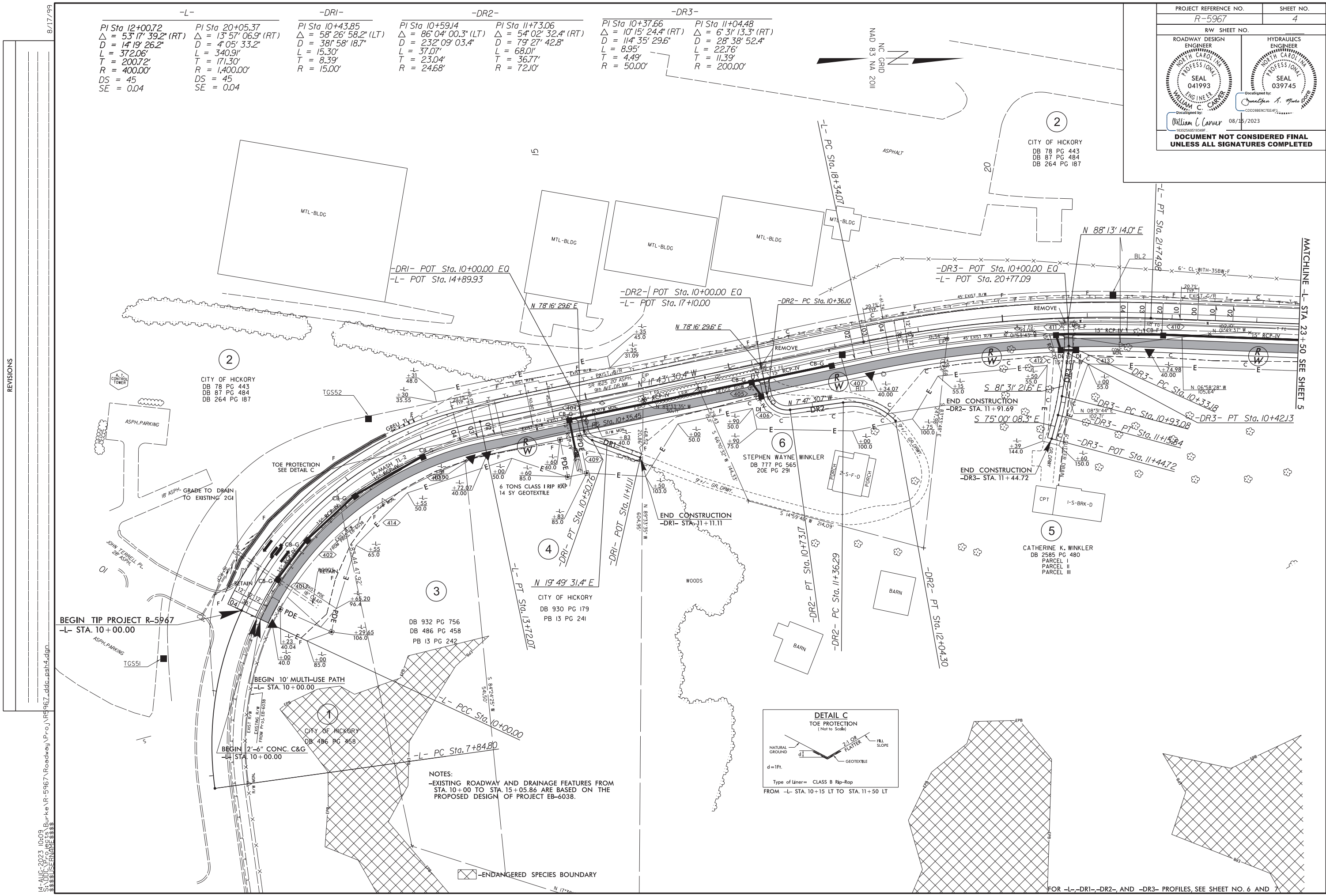

REVISIONS

BEGIN TIP PROJECT R-5967
-L- STA. 10+00.00

BEGIN 10' MULTI-USE PATH
-L- STA. 10+00.00

BEGIN 2'-6" CONC. C&G
-L- STA. 10+00.00

NOTES:
-EXISTING ROADWAY AND DRAINAGE FEATURES FROM STA. 10+00 TO STA. 15+05.86 ARE BASED ON THE PROPOSED DESIGN OF PROJECT EB-6038.

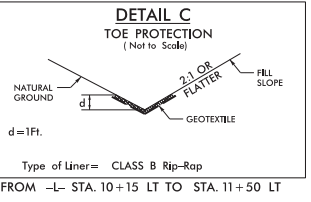

FOR -L-, -DRI-, -DR2-, AND -DR3- PROFILES, SEE SHEET NO. 6 AND 7

8/17/23
 S:\Users\carver\OneDrive - William C. Carver\Projects\5967\Roadway\Proj\R-5967\addc_psh4.dgn
 15-AUG-2023 10:09
 S:\Users\carver\OneDrive - William C. Carver\Projects\5967\Roadway\Proj\R-5967\addc_psh4.dgn
 S:\Users\carver\OneDrive - William C. Carver\Projects\5967\Roadway\Proj\R-5967\addc_psh4.dgn

8/17/99

-L-		-Y-	
PI Sta 32+81.63	PI Sta 37+23.74	PI Sta 10+57.65	PI Sta 13+11.36
$\Delta = 94^{\circ}15'02.6"$ (LT)	$\Delta = 78^{\circ}17'49.1"$ (LT)	$\Delta = 13^{\circ}51'13.0"$ (RT)	$\Delta = 0^{\circ}41'00.0"$ (LT)
D = 15'54'55.8"	D = 19'37'34.3"	D = 13'03'12.2"	D = 0'34'10.0"
L = 592.19'	L = 398.94'	L = 106.13'	L = 120.00'
T = 387.75'	T = 237.66'	T = 53.33'	T = 60.00'
R = 360.00'	R = 291.94'	R = 438.93'	R = 10,061.58'
DS = 45	DS = 45		
SE = 0.06	SE = 0.06		

-DR4-	
PI Sta 10+53.41	PI Sta 11+16.97
$\Delta = 3^{\circ}28'55.0"$ (RT)	$\Delta = 30^{\circ}54'10.6"$ (RT)
D = 28'38'52.4"	D = 45'49'10.9"
L = 12.15'	L = 67.44'
T = 6.08'	T = 34.56'
R = 200.00'	R = 125.05'

PROJECT REFERENCE NO. **R-5967** SHEET NO. **5**

RW SHEET NO. _____ HYDRAULICS ENGINEER

ROADWAY DESIGN ENGINEER SEAL 041993

DocuSigned by: *Jonathan R. Mann*

William C. Carver DD29BE9C7EE4F3...
163525A8519349F

DOCUMENT NOT CONSIDERED FINAL UNLESS ALL SIGNATURES COMPLETED

08/15/2023

RICHARD L. CHRISTOPHER & CHRISTINA L. CHRISTOPHER
ANNIE M.C. ANDERSON
TRACT ONE
0015-E PG 0017
DB 434 PG 399

REVISIONS

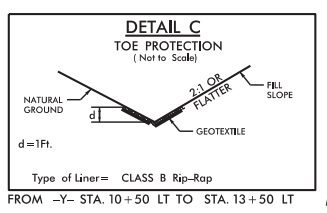
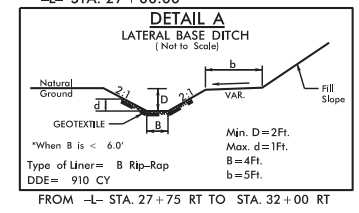
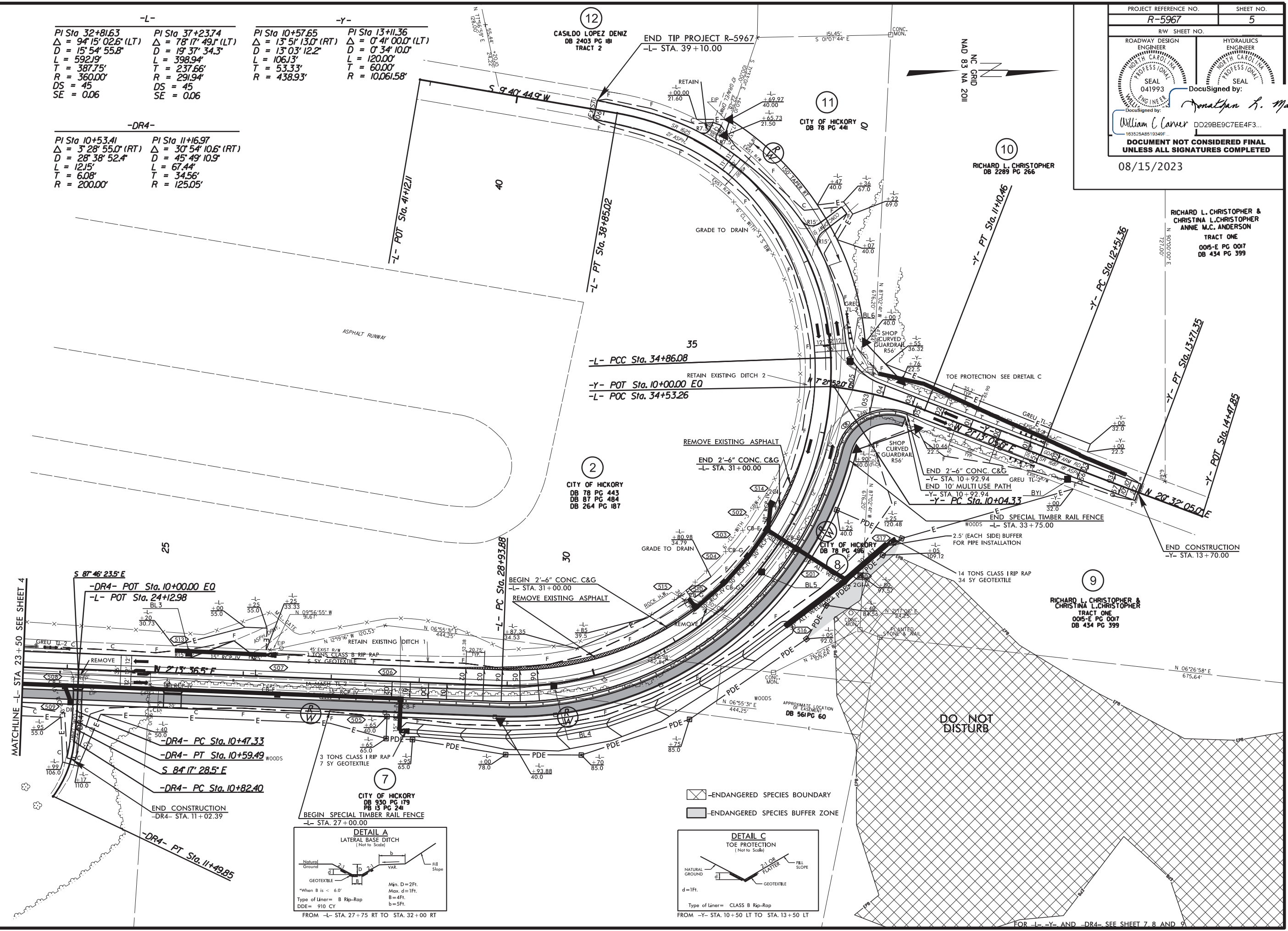

21-JUL-2023 14:44
S:\JUL2023\Projects\Burke\R-5967\Roadway\Proj\RFig7_ddc_pab5.dgn
S:\JUL2023\Projects\Burke\R-5967\Roadway\Proj\RFig7_ddc_pab5.dgn

FOR -L-, -Y-, AND -DR4- SEE SHEET 7, 8 AND 9

5/14/99

PROJECT REFERENCE NO. R-5967	SHEET NO. 6
ROADWAY DESIGN ENGINEER SEAL 041993	HYDRAULICS ENGINEER SEAL 020745
DocuSigned by: <i>William C. Carver</i> 163525A8519349F...	DocuSigned by: <i>Jonathan R. Moore</i> DD29BE9C7EE4F3...

**DOCUMENT NOT CONSIDERED FINAL
UNLESS ALL SIGNATURES COMPLETED**

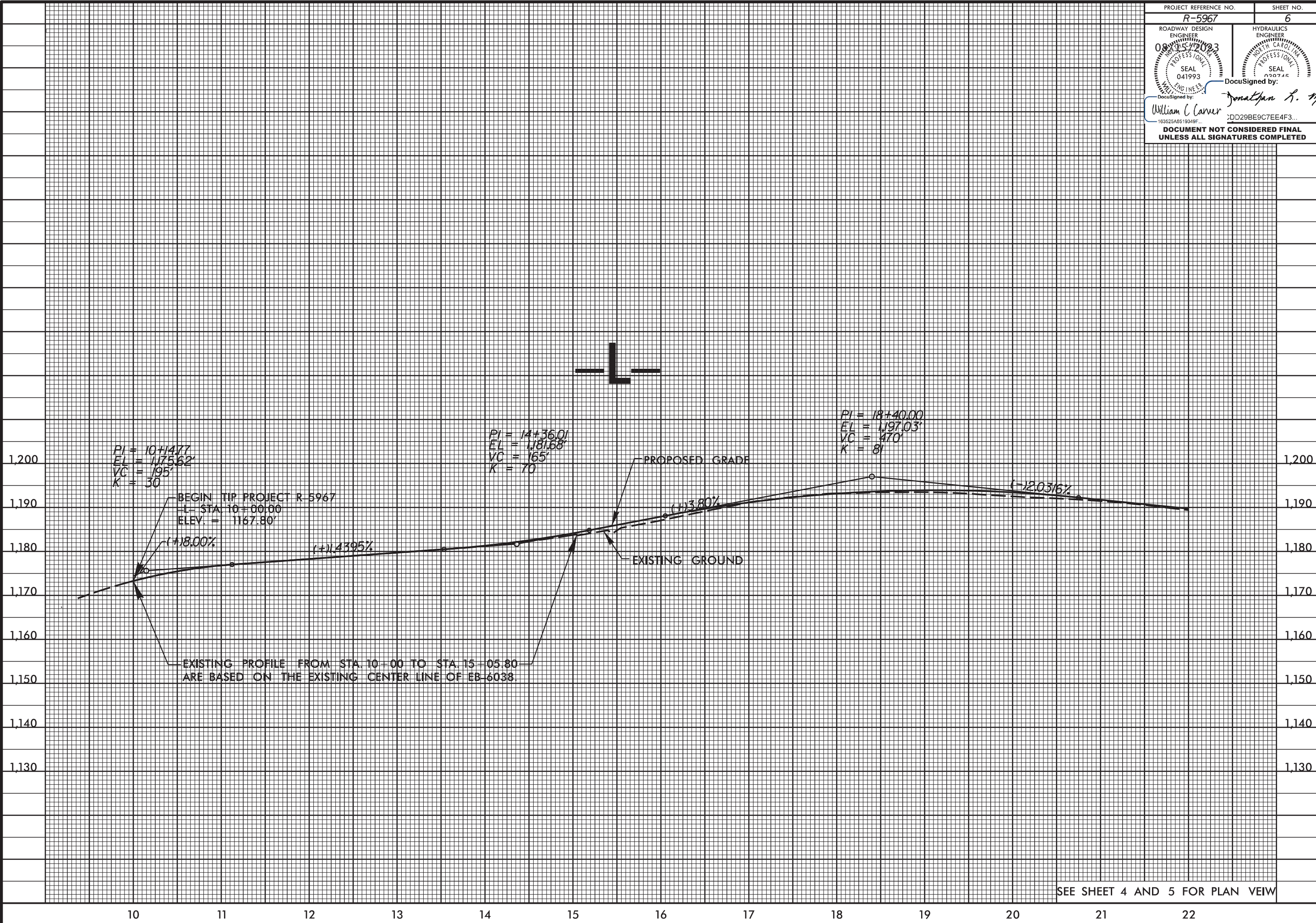

SEE SHEET 4 AND 5 FOR PLAN VIEW

21-JUL-2023 14:48
S:\DCC\Projects\Burke\R-5967\Roadway\Proj\R5967_ddc_p1.dgn

5/14/99

PROJECT REFERENCE NO. R-5967	SHEET NO. 7
ROADWAY DESIGN ENGINEER SEAL 041993 WILLIAM C. CARVER	HYDRAULICS ENGINEER SEAL 039745 JONATHAN R. MOORE
DocuSigned by: William C. Carver	DocuSigned by: Jonathan R. Moore
DOCUMENT NOT CONSIDERED FINAL UNLESS ALL SIGNATURES COMPLETED	

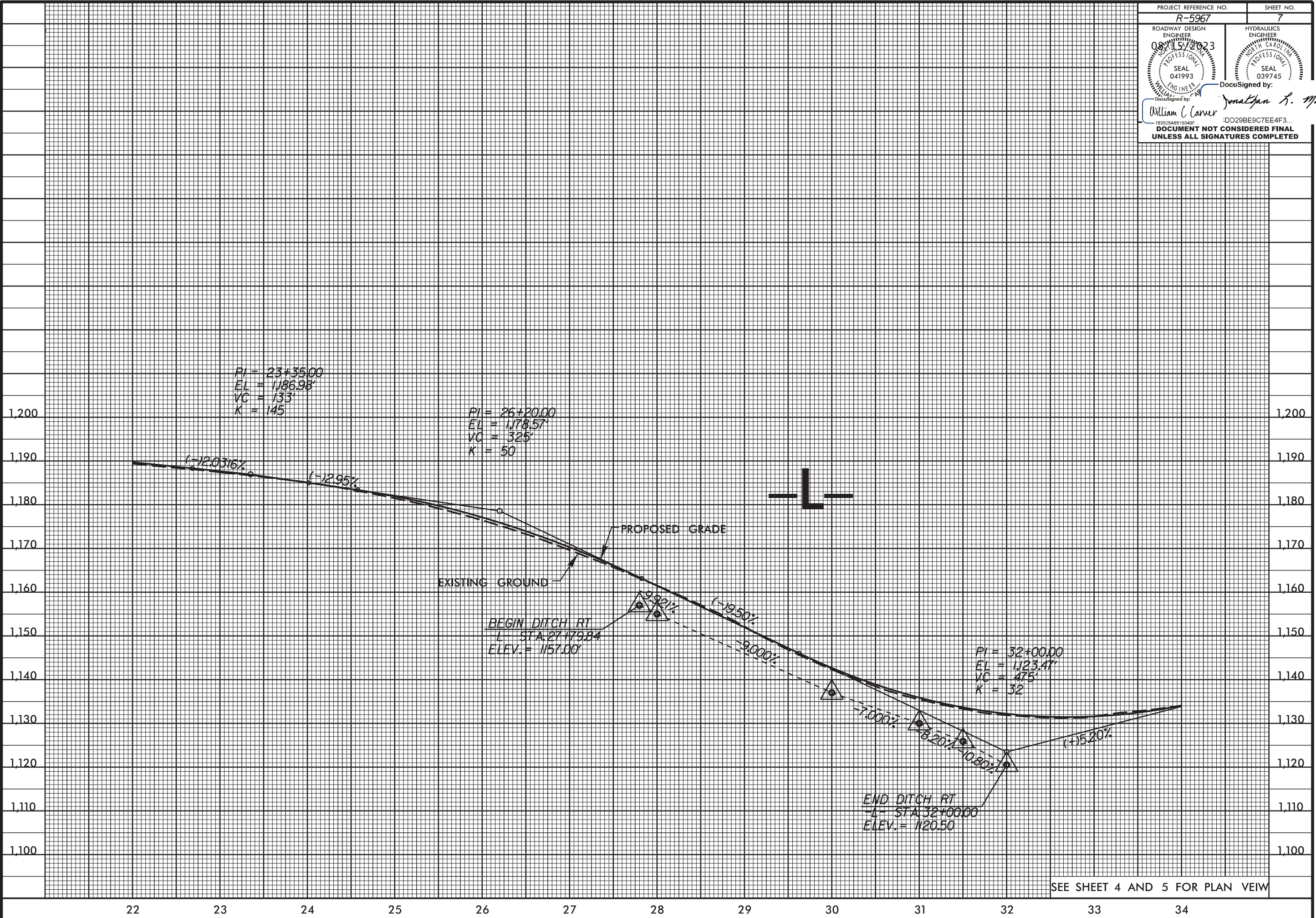

SEE SHEET 4 AND 5 FOR PLAN VIEW

21-JUL-2023 14:49 S:\DCC\Projects\Burke\5967\Roadway\Proj\5967_ddc_pfl.dgn

5/14/99

PROJECT REFERENCE NO. R-5967	SHEET NO. 8
ROADWAY DESIGN ENGINEER 08/14/2023 SEAL 041993	HYDRAULICS ENGINEER SEAL 000745
DocuSigned by: <i>William C. Carver</i> 163525A8519348F...	DocuSigned by: <i>Jonathan R. Moore</i> DD29BE9C7EE4F3...
DOCUMENT NOT CONSIDERED FINAL UNLESS ALL SIGNATURES COMPLETED	

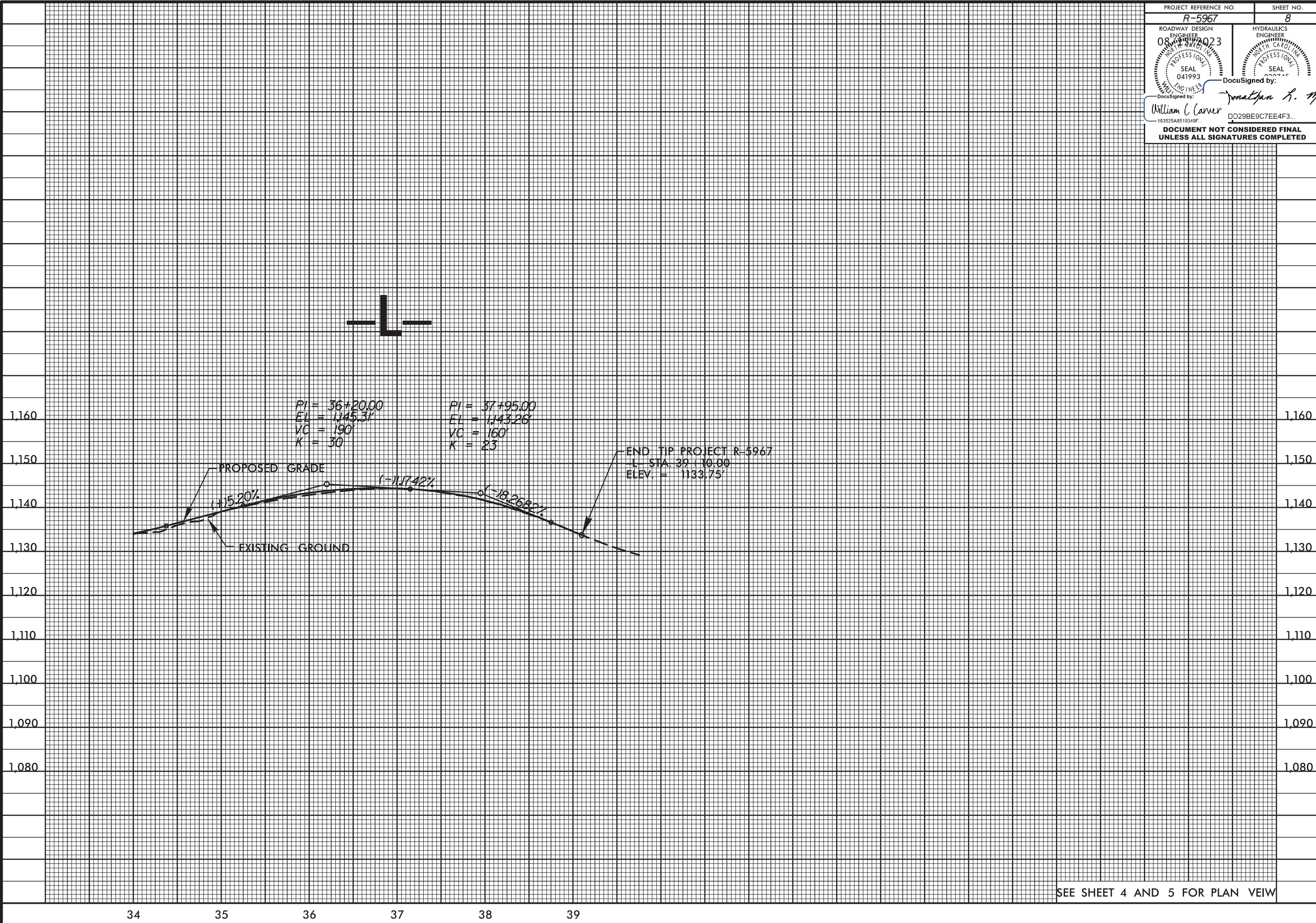

SEE SHEET 4 AND 5 FOR PLAN VIEW

5/28/99

PROJECT REFERENCE NO. R-5967	SHEET NO. 9
ROADWAY DESIGN 08/11/2023	HYDRAULICS ENGINEER
SEAL 041993	DocuSigned by: <i>Jonathan R. Moore</i>
DocuSigned by: <i>William C. Carter</i>	DocuSigned by: <i>William C. Carter</i>
DOCUMENT NOT CONSIDERED FINAL UNLESS ALL SIGNATURES COMPLETED	

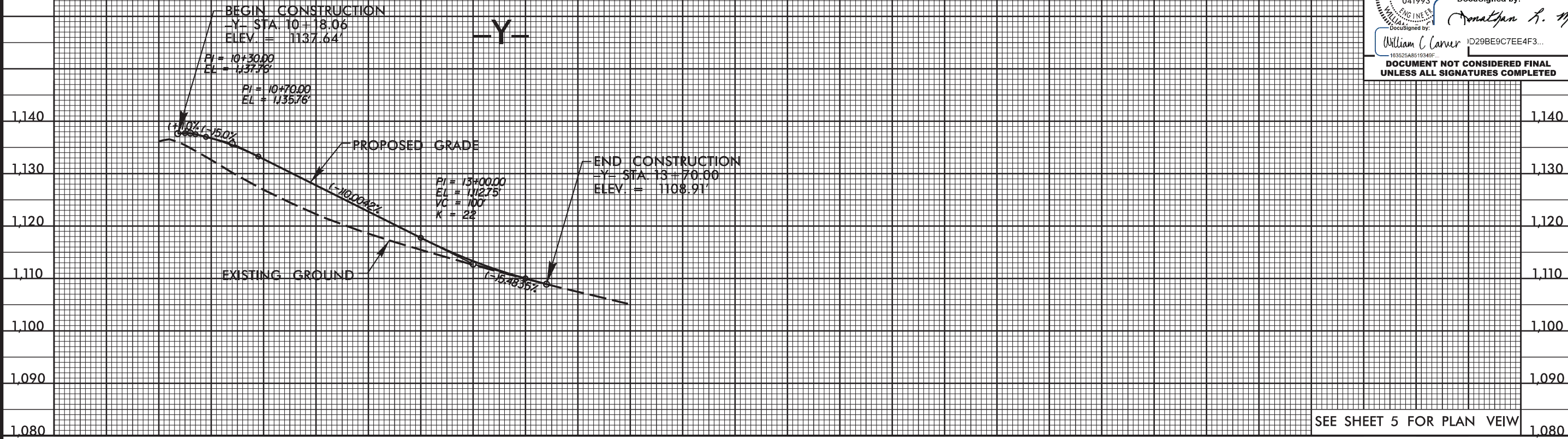

SEE SHEET 5 FOR PLAN VIEW

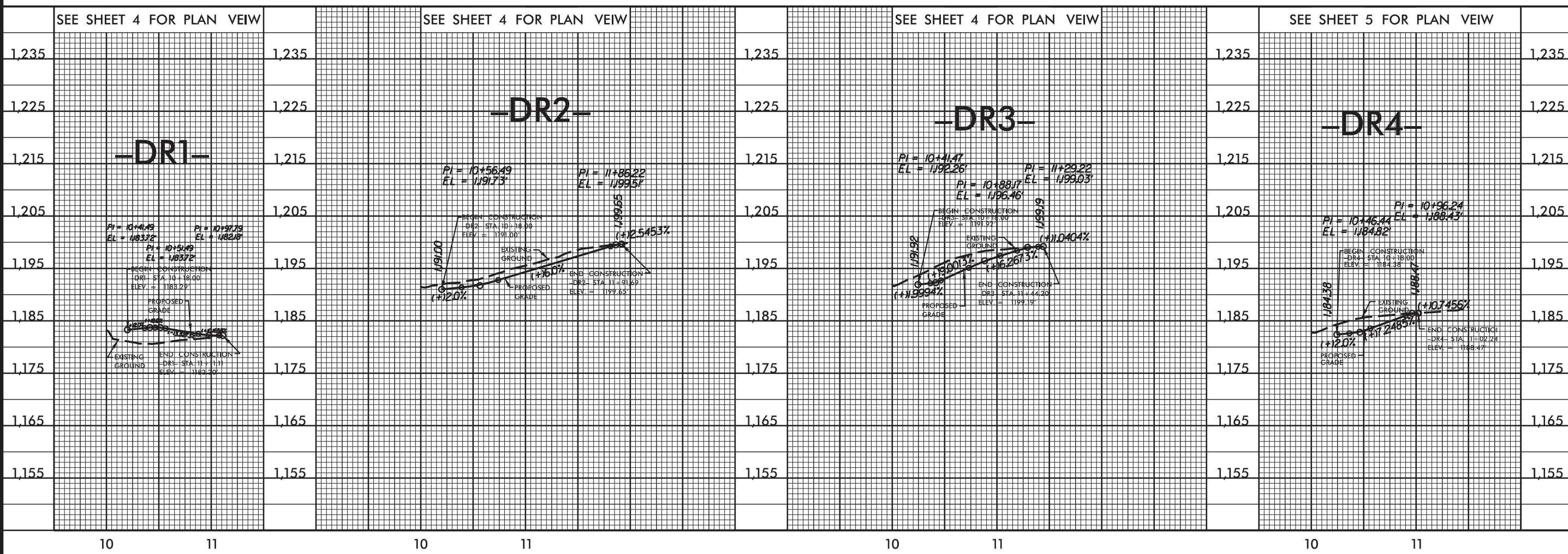

21-JUL-2023 14:50 S:\UDC\Projects\Burke\R-5967\Roadway\Proj\AR5967_ddc_pfl.dgn

09/28/99

STATE OF NORTH CAROLINA DIVISION OF HIGHWAYS

STATE	STATE PROJECT REFERENCE NO.	SHEET NO.	TOTAL SHEETS
N.C.	R-5967	RW01	

BURKE COUNTY

SURVEY CONTROL, CENTERLINES,
RIGHT OF WAY, AND EASEMENTS
LOCATION: SR 1625 (9TH AVE DR NW)



TIP PROJECT: R-5967

CONTRACT:

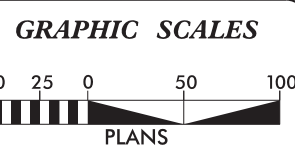
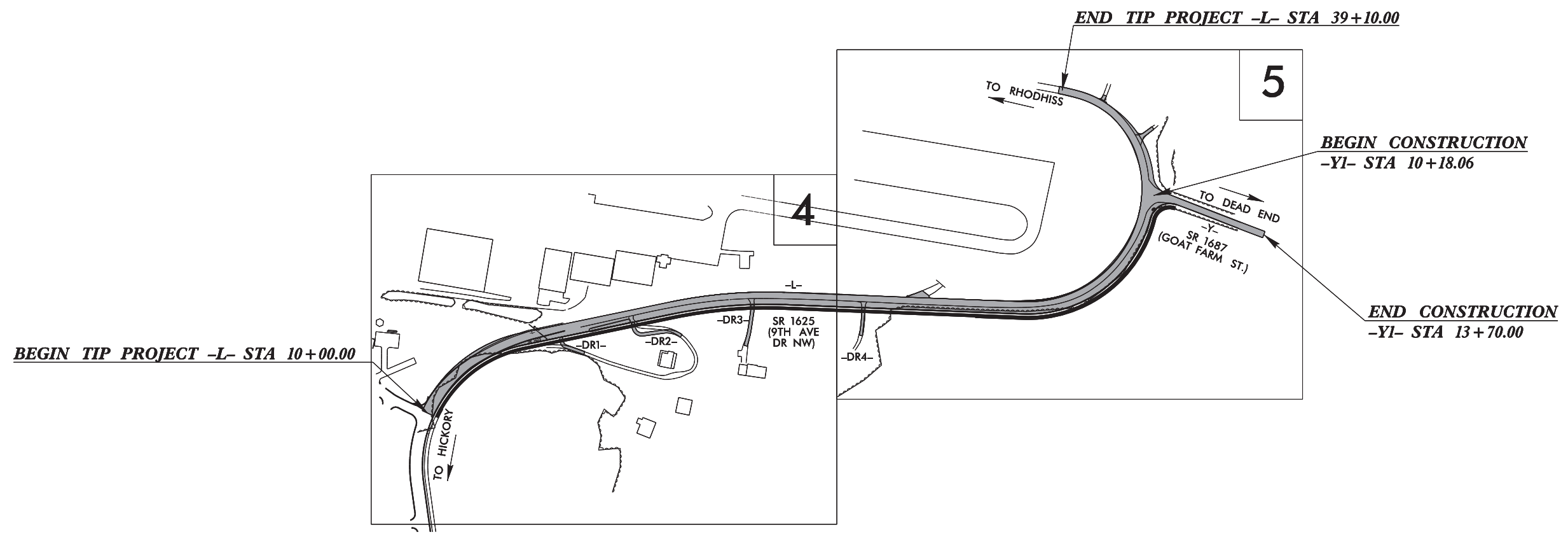

NOTE:
THE CONTROL FOR THIS PROJECT WAS ESTABLISHED FROM PROJECT EB-6038. EXISTING CONTROL POINTS USED WERE *TGS51 AND TGS52*

DATUM DESCRIPTION

THE LOCALIZED COORDINATE SYSTEM DEVELOPED FOR THIS PROJECT IS BASED ON THE STATE PLANE COORDINATES ESTABLISHED BY NCDOT FOR MONUMENT "U4700A-6" WITH NAD 83/NA 2011 STATE PLANE GRID COORDINATES OF
NORTHING: 735458.2657(±ft) EASTING: 1298480.1662(±ft)
ELEVATION: 1072.45(±ft)

THE AVERAGE COMBINED GRID FACTOR USED ON THIS PROJECT (GROUND TO GRID) IS: 0.99986419

THE N.C. LAMBERT GRID BEARING AND LOCALIZED HORIZONTAL GROUND DISTANCE FROM "TGS52" TO -L- STATION 10+00.00 IS
S 56° 28' 53.28" E 271.36'(±ft)

ALL LINEAR DIMENSIONS ARE LOCALIZED HORIZONTAL DISTANCES
VERTICAL DATUM USED IS NAVD 88

Prepared In the Office of:

2024 STANDARD SPECIFICATIONS

RIGHT OF WAY DATE:	LETTING DATE:

PROFESSIONAL LAND SURVEYOR

SIGNATURE: _____ DATE

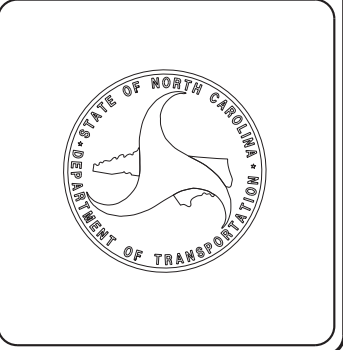

14-NOV-2023, 15:13
S:\DDC\Projects\Burke\R-5967\LocationSurveys\R5967_DDC_RW_TSH.dgn
\$\$\$\$\$SERNAME\$\$\$\$\$

PROJECT REFERENCE NO.	SHEET NO.
R-5967	RW03
RW SHEET NO.	
ROADWAY DESIGN ENGINEER	HYDRAULICS ENGINEER

SURVEY CONTROL SHEET

BASELINE CONTROL, ALIGNMENTS, RIGHT OF WAY

8/17/99
 REVISIONS
 08_FEB_2022_1144
 S:\DIBK\Projects\Burke\5967\LocationSurveys\RF5967.dwg_psh3.dgn
 5967\5967.dwg

ROW MARKER PERMANENT EASEMENT-E

ALIGN	STATION	OFFSET	NORTH	EAST
L	10+23.00	100.00	734233.7801	1291575.5475
L	10+50.00	100.00	734243.9669	1291558.0508
L	10+48.00	40.00	734192.2094	1291527.6558
L	10+23.00	40.00	734180.9390	1291547.1254
L	14+60.00	60.00	734514.9912	1291366.8829
L	14+60.00	40.00	734510.9268	1291347.3002
L	14+83.00	40.00	734533.4469	1291342.6262
L	14+83.00	63.00	734538.1209	1291365.1463
L	27+95.00	65.00	735824.9897	1291293.0038
L	27+95.00	40.00	735825.9611	1291268.0226
L	27+65.00	40.00	735795.9838	1291266.8570
L	27+65.00	65.00	735795.0124	1291291.8381

ROW MARKER IRON PIN AND CAP-E

ALIGN	STATION	OFFSET	NORTH	EAST
L	10+00.00	40.00	734171.6636	1291565.6256
L	13+72.07	40.00	734424.8278	1291365.1698
L	18+34.07	40.00	734877.1937	1291271.2826
L	21+74.98	40.00	735206.4114	1291243.9316
L	28+93.88	40.00	735924.7693	1291271.8648
L	34+11.35	40.00	736334.3918	1290940.7285
Y	10+76.00	22.50	736367.5865	1290929.2955
Y	10+76.00	22.50	736380.5330	1290886.1981
L	35+00.00	40.00	736339.1259	1290842.2394
L	39+00.00	22.50	736046.4318	1290557.2851
L	39+00.00	40.00	736049.3741	1290540.0342

L

POINT	N	E	BEARING	DIST	DELTA	D	L	T	R
PC	734103.883	1291758.641							
CURVE			N 81°27'34.5" W	212.26	32°52'49.7"(RT)	15°16'43.9"	215.20	110.65	375.00
PCC	734135.406	1291548.733							
CURVE			N 38°22'20.0" W	358.80	53°17'39.2"(RT)	14°19'26.2"	372.06	200.72	400.00
PT	734416.699	1291326.004							
LINE			N 11°43'30.4" W	462.01					
PC	734869.065	1291232.117							
CURVE			N 04°44'56.9" W	340.07	13°57'06.9"(RT)	04°05'33.2"	340.91	171.30	1400.00
PT	735207.966	1291203.962							
LINE			N 02°13'36.5" E	718.90					
PC	735926.324	1291231.895							
CURVE			N 44°53'54.8" W	527.65	94°15'02.6"(LT)	15°54'55.8"	592.19	387.75	360.00
PCC	736300.087	1290859.453							
CURVE			S 48°49'39.4" W	368.62	78°17'49.1"(LT)	19°37'34.3"	398.94	237.66	291.94
PT	736057.417	1290581.984							
LINE			S 09°40'44.9" W	227.09					
POT	735833.561	1290543.803							

Y

POINT	N	E	BEARING	DIST	DELTA	D	L	T	R
POT	736299.751	1290892.255							
LINE			N 07°21'52.0" E	4.33					
PC	736304.041	1290892.810							
CURVE			N 14°17'28.5" E	105.87	13°51'13.0"(RT)	13°03'12.2"	106.13	53.33	438.93
PT	736406.637	1290918.944							
LINE			N 21°13'05.0" E	140.90					
PC	736537.984	1290969.938							
CURVE			N 20°52'35.0" E	120.00	00°41'00.0"(LT)	00°34'10.0"	120.00	60.00	10061.58
PT	736650.104	1291012.700							
LINE			N 20°32'05.0" E	76.50					
POT	736721.744	1291039.534							

NOTE: THE CONTROL FOR THIS PROJECT WAS ESTABLISHED FROM PROJECT EB-6038. EXISTING CONTROL POINTS USED WERE TGS51 AND TGS52.

BASELINE CONTROL

BLN	POINT	DESC.	NORTH	EAST	ELEVATION
TGS51		NAIL	734043.3044	1291605.3115	1170.97
TGS52		NAIL	734285.2522	1291322.4985	1176.97
BL1		REBAR & CAP	734843.8030	1291247.0750	1195.20
BL2		REBAR & CAP	735163.2850	1291177.0530	1190.92
BL3		REBAR & CAP	735571.0250	1291195.1130	1179.72
BL4		REBAR & CAP	735985.7330	1291231.7720	1145.90
BL5		REBAR & CAP	736221.3980	1291102.6930	1131.31
BL6		REBAR & CAP	736322.1370	1290863.3700	1136.67
BY1		REBAR & CAP	736568.7040	1290997.6170	1111.78

PROJECT REFERENCE NO.	SHEET NO.
R-5967	RW04
RW SHEET NO.	
ROADWAY DESIGN ENGINEER	HYDRAULICS ENGINEER

SURVEY CONTROL SHEET

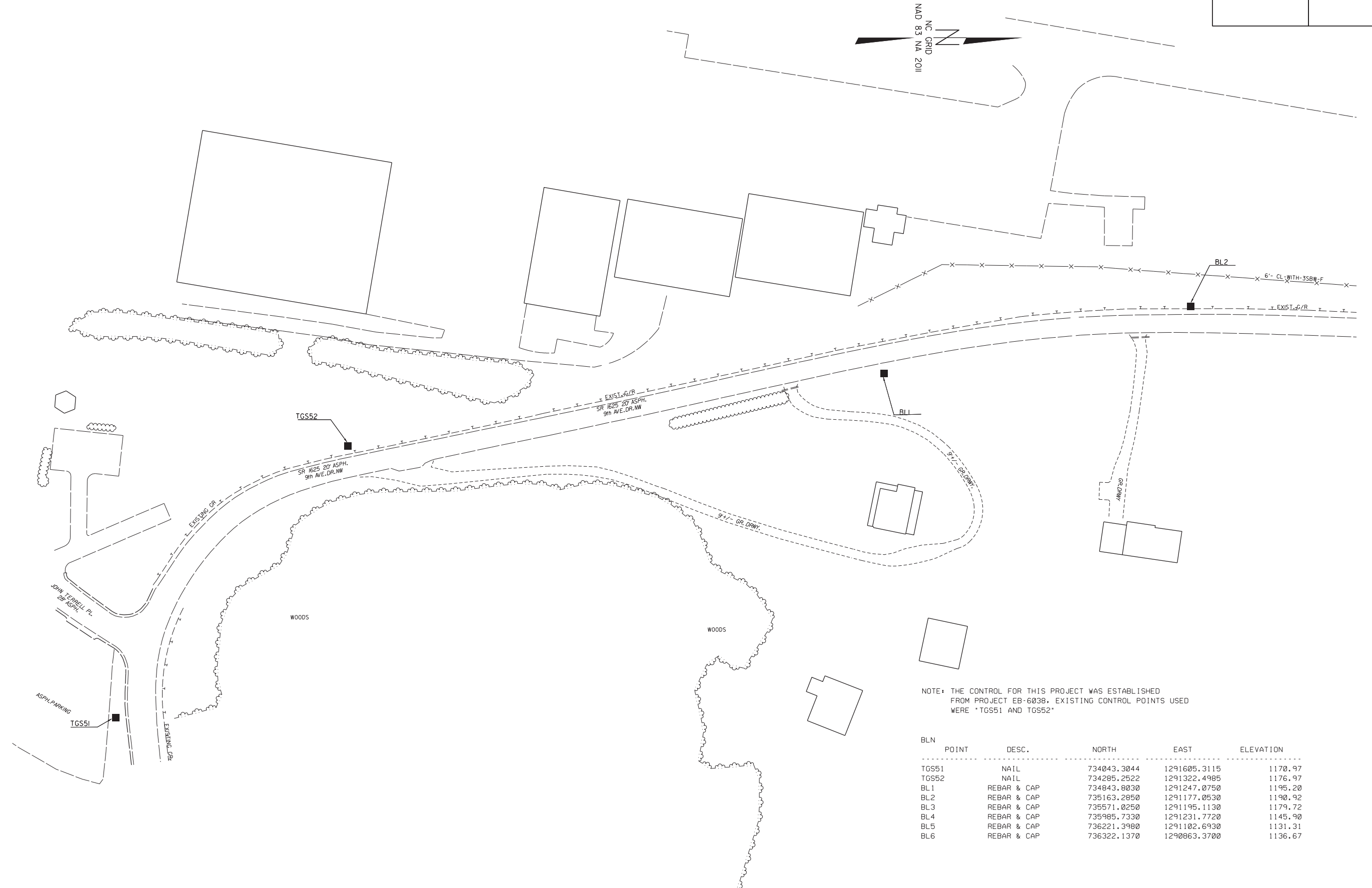

NOTE: THE CONTROL FOR THIS PROJECT WAS ESTABLISHED FROM PROJECT EB-6038. EXISTING CONTROL POINTS USED WERE *TGS51 AND TGS52*

BLN	POINT	DESC.	NORTH	EAST	ELEVATION
	TGS51	NAIL	734043.3044	1291605.3115	1170.97
	TGS52	NAIL	734285.2522	1291322.4985	1176.97
	BL1	REBAR & CAP	734843.8030	1291247.0750	1195.20
	BL2	REBAR & CAP	735163.2850	1291177.0530	1190.92
	BL3	REBAR & CAP	735571.0250	1291195.1130	1179.72
	BL4	REBAR & CAP	735985.7330	1291231.7720	1145.90
	BL5	REBAR & CAP	736221.3980	1291102.6930	1131.31
	BL6	REBAR & CAP	736322.1370	1290863.3700	1136.67

REVISIONS
 08_FEB_2022_ILU
 S:\DIB\Projects\Burrke\R-5967\Locations\Surveys\RE5967_dde_psh_3A.dgn
 8/17/99

PROJECT REFERENCE NO.	SHEET NO.
R-5967	RW05
RW SHEET NO.	
ROADWAY DESIGN ENGINEER	HYDRAULICS ENGINEER

SURVEY CONTROL SHEET

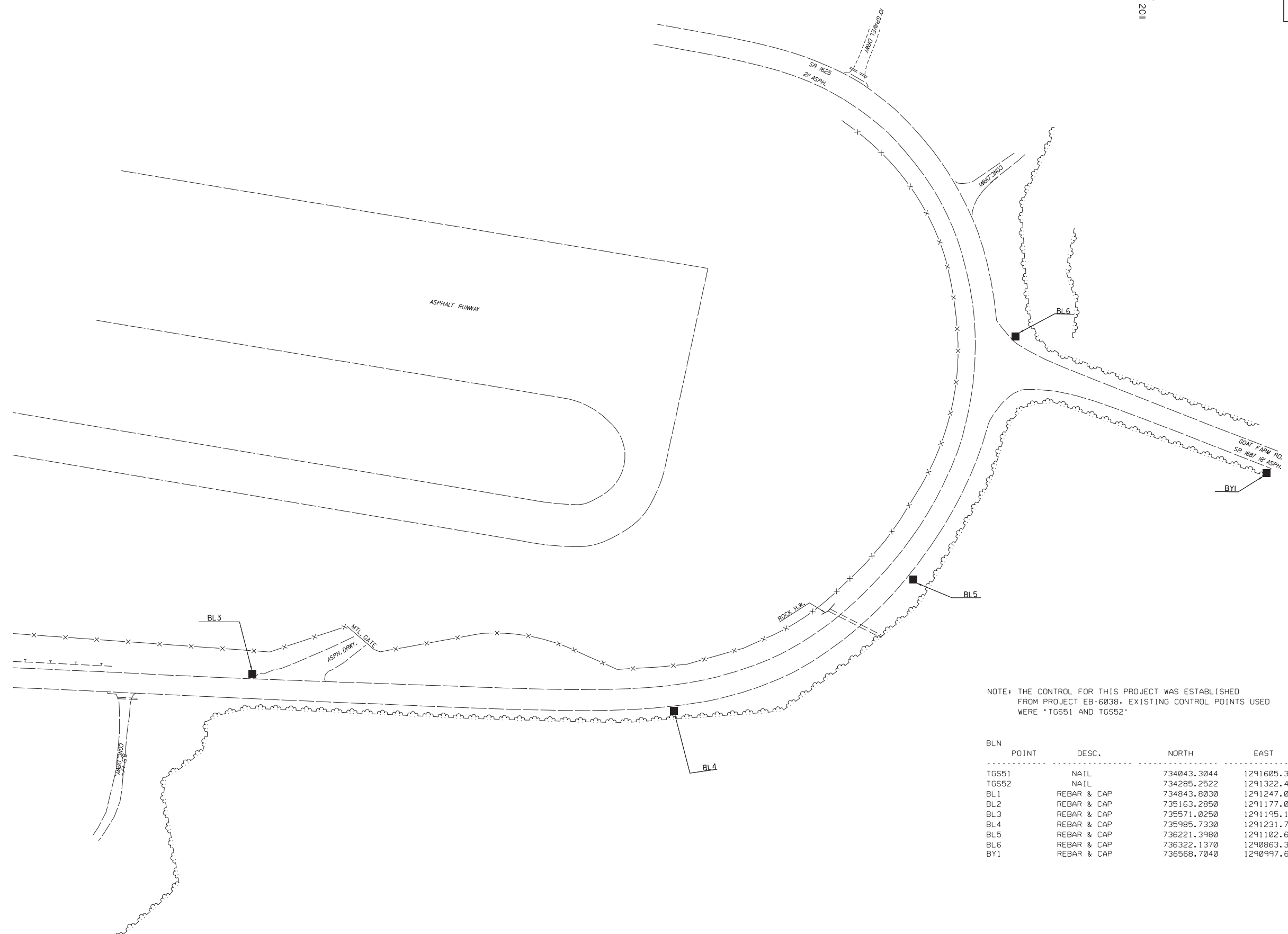
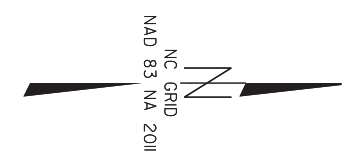

NOTE: THE CONTROL FOR THIS PROJECT WAS ESTABLISHED FROM PROJECT EB-6038. EXISTING CONTROL POINTS USED WERE *TGS51 AND TGS52*

BLN	POINT	DESC.	NORTH	EAST	ELEVATION
	TGS51	NAIL	734043.3044	1291605.3115	1170.97
	TGS52	NAIL	734285.2522	1291322.4985	1176.97
	BL1	REBAR & CAP	734843.8030	1291247.0750	1195.20
	BL2	REBAR & CAP	735163.2850	1291177.0530	1190.92
	BL3	REBAR & CAP	735571.0250	1291195.1130	1179.72
	BL4	REBAR & CAP	735985.7330	1291231.7720	1145.90
	BL5	REBAR & CAP	736221.3980	1291102.6930	1131.31
	BL6	REBAR & CAP	736322.1370	1290863.3700	1136.67
	BY1	REBAR & CAP	736568.7040	1290997.6170	1111.78

REVISIONS
 08_FEB_2022_ILI2
 S:\DIB\Projects\Burke\R-5967\LocationSurveys\RF5967_dde_psh3B.dgn
 8/17/99

ROADWAY STANDARD DRAWINGS

THE FOLLOWING ROADWAY STANDARDS AS SHOWN IN "ROADWAY STANDARD DRAWINGS" - N.C. DEPARTMENT OF TRANSPORTATION - RALEIGH, N.C., DATED JANUARY 2024 ARE APPLICABLE TO THIS PROJECT AND BY REFERENCE HEREBY ARE CONSIDERED A PART OF THESE PLANS:

STD. NO.	TITLE
1101.01	WORK ZONE WARNING SIGNS
1101.02	TEMPORARY LANE CLOSURES
1101.04	TEMPORARY SHOULDER CLOSURES
1101.05	WORK ZONE VEHICLE ACCESSES
1101.11	TRAFFIC CONTROL DESIGN TABLES
1110.01	STATIONARY WORK ZONE SIGNS
1110.02	PORTABLE WORK ZONE SIGNS
1115.01	FLASHING ARROW BOARDS
1130.01	DRUMS
1135.01	CONES
1145.01	BARRICADES
1150.01	FLAGGING DEVICES
1170.01	PORTABLE CONCRETE BARRIER
1160.01	TEMPORARY CRASH CUSHION
1165.01	TRUCK MOUNTED ATTENUATOR
1170.01	PORTABLE CONCRETE BARRIER
1205.01	PAVEMENT MARKINGS - LINE TYPES AND OFFSETS
1205.02	PAVEMENT MARKINGS - TWO LANE AND MULTILANE ROADWAYS
1205.04	PAVEMENT MARKINGS - INTERSECTIONS
1205.05	PAVEMENT MARKINGS - TURN LANES
1261.01	GUARDRAIL AND BARRIER DELINEATORS - INSTALLATION SPACING
1261.02	GUARDRAIL AND BARRIER DELINEATORS - TYPES AND MOUNTING
1262.01	GUARDRAIL END DELINEATION

LEGEND

GENERAL

- DIRECTION OF TRAFFIC FLOW
- DIRECTION OF PEDESTRIAN TRAFFIC FLOW
- EXIST. PVMT.
- NORTH ARROW
- PROPOSED PVMT.
- TEMP. SHORING (LOCATION PURPOSES ONLY)

WORK AREA

REMOVAL

TEMPORARY PAVEMENT

SIGNALS

- EXISTING
- PROPOSED
- TEMPORARY

PORTABLE TRAFFIC SIGNAL

PAVEMENT MARKINGS

- EXISTING LINES
- TEMPORARY LINES

TEMPORARY PAVEMENT MARKING

- 24" WHITE STOP BAR
- DOUBLE YELLOW

TRAFFIC CONTROL DEVICES

- BARRICADE (TYPE III)
- CONE
- DRUM
- SKINNY DRUM
- TUBULAR MARKER
- TEMPORARY CRASH CUSHION
- FLASHING ARROW BOARD
- FLAGGER
- LAW ENFORCEMENT
- TRUCK MOUNTED ATTENUATOR (TMA)
- CHANGEABLE MESSAGE SIGN

TEMPORARY SIGNING

- PORTABLE SIGN
- STATIONARY SIGN
- STATIONARY OR PORTABLE SIGN

PAVEMENT MARKERS

- CRYSTAL/CRYSTAL
- CRYSTAL/RED
- YELLOW/YELLOW

PAVEMENT MARKING SYMBOLS

- PAVEMENT MARKING SYMBOLS

I7-OCT-2023 14:21 S:\DDC\Projects\Burke\NR-5967\Trcfic\TCP\NR-5967_ddc_TC_TMP_TMPIA.dgn \$\$\$USERNAME\$\$\$

APPROVED: DATE: 10/17/2023 SEAL 		ROADWAY STANDARD DRAWINGS & LEGEND
DOCUMENT NOT CONSIDERED FINAL UNLESS ALL SIGNATURES COMPLETED		

GENERAL NOTES

CHANGES MAY BE REQUIRED WHEN PHYSICAL DIMENSIONS IN THE DETAIL DRAWINGS, STANDARD DETAILS AND ROADWAY DETAILS ARE NOT ATTAINABLE TO MEET FIELD CONDITIONS, OR RESULT IN DUPLICATE, OR UNDESIRED OVERLAPPING OF DEVICES. MODIFICATION MAY INCLUDE: MOVING, SUPPLEMENTING, COVERING OR REMOVAL OF DEVICES, AS DIRECTED BY THE

THE FOLLOWING GENERAL NOTES APPLY AT ALL TIMES FOR THE DURATION OF THE CONSTRUCTION PROJECT, EXCEPT WHEN OTHERWISE NOTED IN THE PLAN, OR DIRECTED BY THE ENGINEER.

TIME RESTRICTIONS

A) DO NOT STOP TRAFFIC AS FOLLOWS:

B) <u>ROAD NAME</u>	<u>ROAD NAME</u>
SR 1625 (-L-) 9TH AVE DR NW	30 MINS. , 60 MINS. FOR TRAFFIC SHIFTS,
SR 1687 (-Y-) GOAT FARM ROAD	PLACEMENT OF PAVEMENT MARKINGS AND TIE-IN WORK.

C) HOLIDAY

1. FOR ANY UNEXPECTED OCCURRENCE THAT CREATES UNUSUALLY HIGH TRAFFIC VOLUMES, AS DIRECTED BY THE ENGINEER.
2. FOR NEW YEAR'S, BETWEEN THE HOURS OF 3:00 P.M. DECEMBER 31st TO 7:00 A.M. JANUARY 2ND. IF NEW YEAR'S DAY IS ON A FRIDAY, SATURDAY, SUNDAY, OR MONDAY THEN UNTIL 7:00 A.M. THE FOLLOWING TUESDAY.
3. FOR EASTER, BETWEEN THE HOURS OF 3:00 P.M. THURSDAY TO 7:00 A.M. MONDAY.
4. FOR MEMORIAL DAY, BETWEEN THE HOURS OF 3:00 P.M. FRIDAY TO 7:00 A.M. TUESDAY.
5. FOR INDEPENDENCE DAY, BETWEEN THE HOURS OF 3:00 P.M. THE DAY BEFORE INDEPENDENCE DAY AND 7:00 A.M. THE DAY AFTER INDEPENDENCE DAY.
IF INDEPENDENCE DAY IS ON A FRIDAY, SATURDAY, SUNDAY OR MONDAY THEN BETWEEN THE HOURS OF 3:00 P.M. THE THURSDAY BEFORE INDEPENDENCE DAY AND 7:00 A.M. THE TUESDAY AFTER INDEPENDENCE DAY.
6. FOR LABOR DAY, BETWEEN THE HOURS OF 3:00 P.M. FRIDAY TO 7:00 A.M. TUESDAY.
7. FOR THANKSGIVING DAY, BETWEEN THE HOURS OF 3:00 P.M. TUESDAY TO 7:00 A.M. MONDAY.
8. FOR CHRISTMAS, BETWEEN THE HOURS OF 3:00 P.M. THE FRIDAY BEFORE THE WEEK OF CHRISTMAS DAY AND 7:00 A.M. THE FOLLOWING TUESDAY AFTER THE WEEK OF CHRISTMAS.

LANE AND SHOULDER CLOSURE REQUIREMENTS

- D) REMOVE LANE CLOSURE DEVICES FROM THE LANE WHEN WORK IS NOT BEING PERFORMED BEHIND THE LANE CLOSURE OR WHEN A LANE CLOSURE IS NO LONGER NEEDED, OR AS DIRECTED BY THE ENGINEER.
- E) WHEN PERSONNEL AND/OR EQUIPMENT ARE WORKING WITHIN 15' OF AN OPEN TRAVEL LANE, CLOSE THE NEAREST OPENSHOULDER USING ROADWAY STANDARD DRAWING NO. 1101.04 UNLESS THE WORK AREA IS PROTECTED BY BARRIER OR GUARDRAIL OR A LANE CLOSURE IS INSTALLED.
- F) WHEN PERSONNEL AND/OR EQUIPMENT ARE WORKING ON THE SHOULDER ADJACENT TO A DIVIDED FACILITY AND WITHIN 5 FT OF AN OPEN TRAVEL LANE, CLOSE THE NEAREST OPEN TRAVEL LANE USING ROADWAY STANDARD DRAWING NO. 1101.02 UNLESS THE WORK AREA IS PROTECTED BY BARRIER OR GUARDRAIL.
- WHEN PERSONNEL AND/OR EQUIPMENT ARE WORKING ON THE SHOULDER ADJACENT TO A DIVIDED FACILITY AND WITHIN 10 FT OF AN OPEN TRAVEL LANE, CLOSE THE NEAREST OPEN TRAVEL LANE USING ROADWAY STANDARD DRAWING NO. 1101.02 UNLESS THE WORK AREA IS PROTECTED BY BARRIER OR GUARDRAIL.
- G) WHEN PERSONNEL AND/OR EQUIPMENT ARE WORKING WITHIN A LANE OF TRAVEL OF AN UNDIVIDED OR DIVIDED FACILITY, CLOSE THE LANE ACCORDING TO THE TRAFFIC CONTROL PLANS, ROADWAY STANDARD DRAWINGS OR AS DIRECTED BY THE ENGINEER. CONDUCT THE WORK SO THAT ALL PERSONNEL AND/OR EQUIPMENT REMAIN WITHIN THE CLOSED TRAVEL LANE.
- H) DO NOT INSTALL MORE THAN ONE LANE CLOSURE IN ANY ONE DIRECTION ON SR 1625

PAVEMENT EDGE DROP OFF REQUIREMENTS

- I) BACKFILL AT A 6:1 SLOPE UP TO THE EDGE AND ELEVATION OF EXISTING PAVEMENT IN AREAS ADJACENT TO AN OPENED TRAVEL LANE THAT HAS AN EDGE OF PAVEMENT DROP-OFF AS FOLLOWS:
BACKFILL DROP-OFFS THAT EXCEED 2 INCHES ON ROADWAYS WITH POSTED SPEED LIMITS OF 45 MPH OR GREATER.
BACKFILL DROP-OFFS THAT EXCEED 3 INCHES ON ROADWAYS WITH POSTED SPEED LIMITS LESS THAN 45 MPH.
BACKFILL WITH SUITABLE COMPACTED MATERIAL, AS APPROVED BY THE ENGINEER, AT NO EXPENSE TO THE DEPARTMENT.
- J) DO NOT EXCEED A DIFFERENCE OF 2 INCHES IN ELEVATION BETWEEN OPEN LANES OF TRAFFIC FOR NOMINAL LIFTS OF 1.5 INCHES. INSTALL ADVANCE WARNING "UNEVEN LANES" SIGNS (W8-11) 350 FT. IN ADVANCE AND A MINIMUM OF EVERY HALF MILE THROUGHOUT THE UNEVEN AREA.

TRAFFIC PATTERN ALTERATIONS

- K) NOTIFY THE ENGINEER THIRTY (30) CALENDAR DAYS PRIOR TO ANY TRAFFIC PATTERN ALTERATION.

SIGNING

- L) INSTALL ADVANCE WORK ZONE WARNING SIGNS WHEN WORK IS WITHIN 40 FT FROM THE EDGE OF TRAVEL LANE AND NO MORE THAN THREE (3) DAYS PRIOR TO THE BEGINNING OF CONSTRUCTION.
- M) ENSURE ALL NECESSARY SIGNING IS IN PLACE PRIOR TO ALTERING ANY TRAFFIC PATTERN.
- N) INSTALL BLACK ON ORANGE "DIP" SIGNS (W8-2) AND/OR "BUMP" SIGNS (W8-1) 350 FT. IN ADVANCE OF THE UNEVEN AREA, OR AS DIRECTED BY THE ENGINEER.

TRAFFIC CONTROL DEVICES



- O) WHEN LANE CLOSURES ARE NOT IN EFFECT SPACE CHANNELIZING DEVICES IN WORK AREAS NO GREATER IN FEET THAN TWICE THE POSTED SPEED LIMIT (MPH) EXCEPT, 10 FT ON-CENTER IN RADII, AND 3 FT OFF THE EDGE OF AN OPEN TRAVELWAY. REFER TO STANDARD SPECIFICATIONS FOR ROADS AND STRUCTURES SECTIONS 1130 (DRUMS), 1135 (CONES) AND 1180 (SKINNY DRUMS) FOR ADDITIONAL REQUIREMENTS.
- P) PLACE TYPE III BARRICADES, WITH "ROAD CLOSED" SIGN R11-2 ATTACHED, OF SUFFICIENT LENGTH TO CLOSE ENTIRE ROADWAY

PAVEMENT MARKINGS AND MARKERS

- Q) INSTALL TEMPORARY PAVEMENT MARKINGS AND TEMPORARY PAVEMENT MARKERS ON INTERIM LAYERS OF PAVEMENT AS FOLLOWS:
- | ROAD NAME | MARKING | MARKER |
|---------------|---------|--------|
| US 1625 (-L-) | PAINT | NONE |
| SR 1687 (-Y-) | PAINT | NONE |
- R) PLACE ONE APPLICATION OF PAINT FOR TEMPORARY TRAFFIC PATTERNS. PLACE A SECOND APPLICATION OF PAINT SIX (6) MONTHS AFTER THE INITIAL APPLICATION AND EVERY SIX MONTHS AS DIRECTED BY THE ENGINEER.
- S) TIE PROPOSED PAVEMENT MARKING LINES TO EXISTING PAVEMENT MARKING LINES.
- T) REMOVE/REPLACE ANY CONFLICTING/DAMAGED PAVEMENT MARKINGS AND MARKERS BY THE END OF EACH DAY'S OPERATION.

LOCAL NOTES:

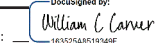
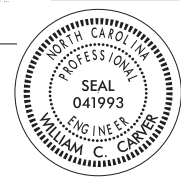
- 1) EMERGENCY VEHICLE ACCESS MUST BE MAINTAINED AT ALL TIMES.
- 2) NOTIFY THE BURKE COUNTY SCHOOL BOARD, FIRE DEPARTMENT, AND EMS 30 DAYS BEFORE ANY LANE CLOSURES.
- 3) DRIVEWAYS MUST MAINTAIN ACCESS AT ALL TIMES.

APPROVED:  DATE: 08/15/2023 SEAL			<h2 style="margin: 0;">TRANSPORTATION OPERATIONS PLAN</h2>
DOCUMENT NOT CONSIDERED FINAL UNLESS ALL SIGNATURES COMPLETED			

PROJECT PHASING

PHASE I

STEP 1

ERECT WORK ZONE ADVANCE WARNING SIGNS ON -L- 9TH AVE DR NW AND -Y- SR 1687 (GOAT FARM ST.). SEE RDWY STD. 1101.01 AND TMP-3 AND TMP-4.

STEP 2

USING RDWY STD 1101.04, AND FLAGGERS AS NECESSARY, CONSTRUCT TEMPORARY PAVEMENT OF -Y-, AS FOLLOWS:
SEE TMP-4

-Y- STA. 10+50 +/- TO -Y- STA. 13+70 +/-

PHASE II

STEP 1

USING RDWY STD. 1101.02 (SEE 14 OF 14), AND FLAGGERS AS NECESSARY, INSTALL AND ACTIVATE PORTABLE TRAFFIC SIGNALS, STOP BARS, AND PORTABLE SIGNS ON -L- AND -Y-. SEE TMP-6

STEP 2

USING RDWY STD. 1101.02 (SHEET 1 OF 14), AND FLAGGERS AS NECESSARY, CONSTRUCT PROPOSED -Y- UP TO, BUT NOT INCLUDING THE FINAL LAYER OF SURFACE COURSE, AS FOLLOWS:
SEE TMP-6

-Y- STA. 10+20 +/- TO -Y- STA. 13+70 +/- (RIGHT SIDE ONLY).

-INSTALL TEMPORARY PCB (ANCHORED) AND TEMPORARY CRASH CUSHION FROM -Y- STA. 10+20 +/- TO -Y- STA. 13+70 +/-

-INSTALL PROPOSED GUARDRAIL FROM -Y- STA. 10+50 +/- TO -Y- STA. 12+50 +/- (RIGHT SIDE ONLY)

STEP 3

USING RDWY STD 1101.04, AND FLAGGERS AS NECESSARY, CONSTRUCT PROPOSED -L- UP TO, BUT NOT INCLUDING THE FINAL LAYER OF SURFACE COURSE, AS FOLLOWS:
SEE TMP-5 AND TMP-6.

-L- STA. 10+00 +/- TO -L- STA. 34+25 +/- (RIGHT SIDE ONLY).

-PROPOSED CURB AND GUTTER FROM -L- STA. 10+00 +/- TO 34+25 +/- (RIGHT SIDE ONLY).

-PROPOSED MULTIUSE PATH FROM -L- STA. 10+00 +/- TO 34+25 +/- (RIGHT SIDE ONLY).

-PROPOSED DOUBLEFACE GUADRAIL AND ATTENUATOR FROM -L- STA. 10+00 +/- TO 34+25 +/- (RIGHT SIDE ONLY).

PHASE III

STEP 1

DEACTIVATE PORTABLE SIGNAL SYSTEM.

STEP 2

USING RDWY STD. 1101.02, AND FLAGGERS AS NECESSARY, SWITCH TRAFFIC TO RIGHT SIDE OF -Y-.
SEE TMP-7 AND TMP-8

STEP 3

ACTIVATE PORTABLE SIGNAL

STEP 4

CONSTRUCT PROPOSED -Y- FROM -Y- STA. 10+20 +/- TO -Y- STA. 13+70 +/- UP TO, BUT NOT INCLUDING THE FINAL LAYER OF SURFACE COURSE, AS FOLLOWS:
SEE TMP-8

-Y- STA. 10+20 +/- TO -Y- STA. 13+70 +/- (LEFT SIDE ONLY)

-PROPOSED GUARDRAIL FROM -Y- STA. 10+50 +/- TO 12+50 +/- (LEFT SIDE ONLY)

STEP 5

USING RDWY STD. 1101.02 (SHEET 1 OF 14), AND FLAGGERS IF NECESSARY, SWITCH TRAFFIC TO THE EASTBOUND LANES.

STEP 6

CONSTRUCT PROPOSED -L- FROM -L- STA. 10+00 +/- TO -L- STA. 34+25 +/- UP TO, BUT NOT INCLUDING THE FINAL LAYER OF SURFACE COURSE, AS FOLLOWS:
SEE TMP-7 AND TMP-8

-L- STA. 10+00 TO -L- STA. 34+25 +/- (LEFT SIDE ONLY)

-PROPOSED GUARDRAIL FROM -L- STA. 12+75 +/- TO 24+00 +/- (LEFT SIDE ONLY)

STEP 7

CONSTRUCT PROPOSED -L- FROM -L- STA. 34+25 +/- TO -L- STA. 39+10 +/- UP TO, BUT NOT INCLUDING THE FINAL SURFACE COURSE, AS FOLLOWS:
SEE TMP-8

-L- STA. 33+00 +/- TO -L- STA. 39+10 +/- (RIGHT SIDE ONLY).

-PROPOSED GUARDRAIL FROM -L- STA. 34+25 +/- TO -L- STA. 35+35 +/-

PHASE IV

STEP 1

USING RDWY STD. 1101.02, (SHEET 2 OF 14) AND FLAGGERS IF NECESSARY, COMPLETE THE FOLLOWING:
SEE SHEETS TMP-9 AND TMP-10.

-INSTALL PROPOSED GUARDRAIL FROM -Y- STA. 10+50 +/- TO -Y- STA. 12+50 +/- (LEFT SIDE ONLY)

-REMOVE TEMPORARY PCB AND TEMPORARY CRASH CUSHION

-CONSTRUCT TIE-INS

-PLACE FINAL LAYER OR SURFACE COURSE

-PLACE FINAL PAVEMENT MARKINGS ON THE ENTIRE PROJECT (SEE PAVEMENT MARKING PLANS)



STEP 2

USING RDWY STD. 1101.02 (SHEET 2 OF 14), AND FLAGGERS AS NECESSARY, REMOVE ALL TRAFFIC CONTROL DEVICES AND ADVANCE WARNING SIGNS.

-OPEN ALL ROADS TO THEIR FINAL PATTERN.

-OPEN MULTIUSE PATH.

28-AUG-2023 10:36 S:\DDC\Projects\Burr-ke\NR-5967\Traf\Traf\TC\TC\TMP-2.dgn \$\$\$USERNAME\$\$\$

APPROVED: <u>William C. Carver</u> <small>183625A8519349F...</small> DATE: 08/28/2023 <div style="text-align: center;">  SEAL </div>		<h2 style="margin: 0;">TRANSPORTATION OPERATIONS PLAN</h2>
DOCUMENT NOT CONSIDERED FINAL UNLESS ALL SIGNATURES COMPLETED		

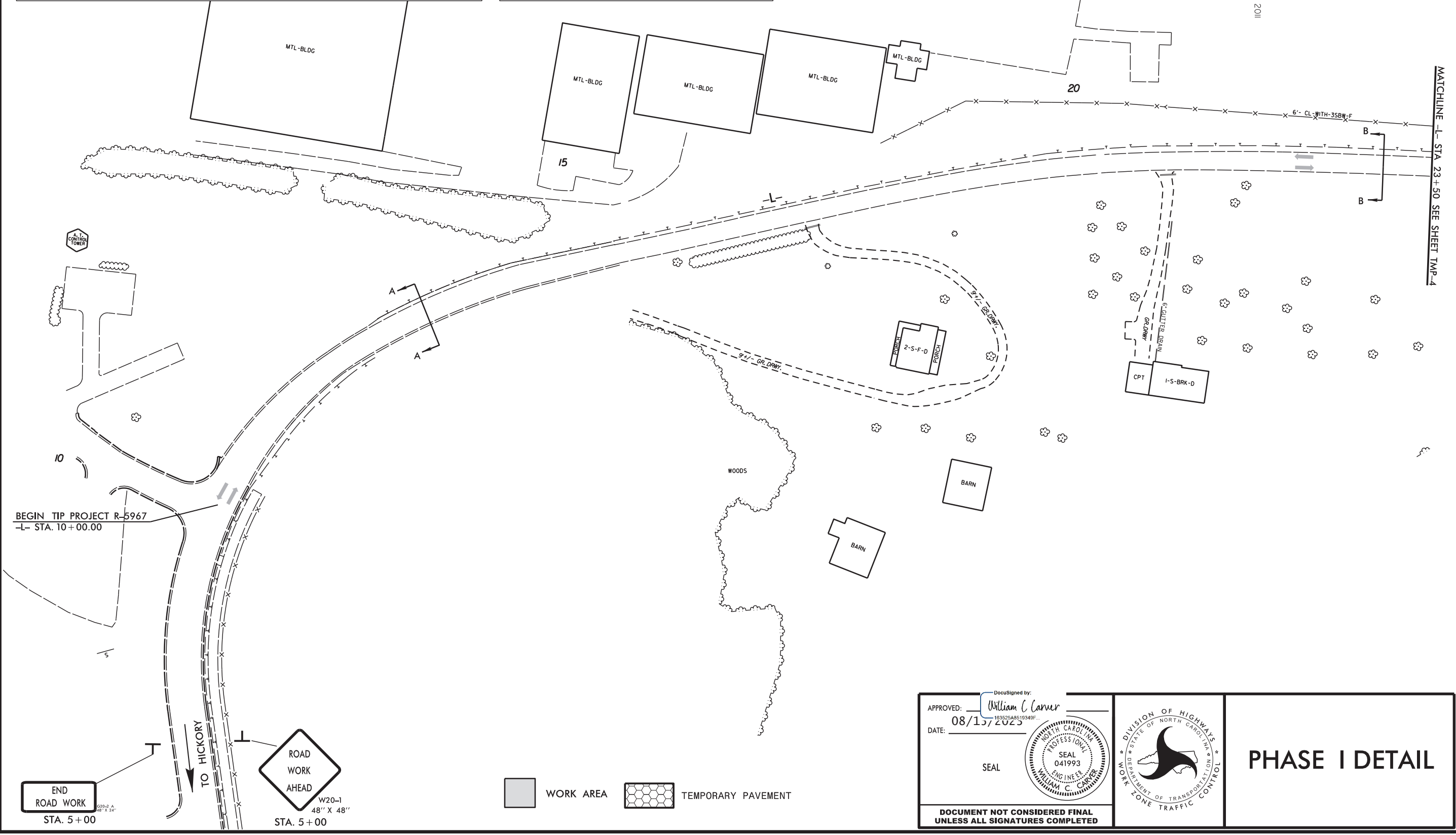
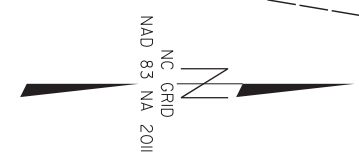
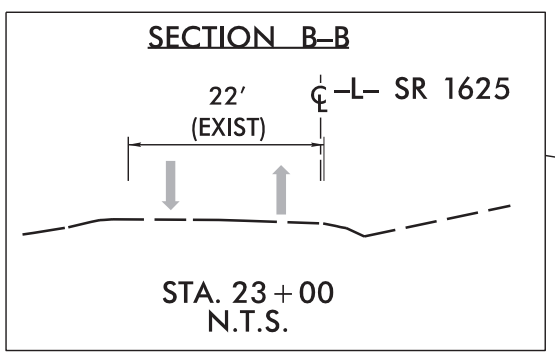
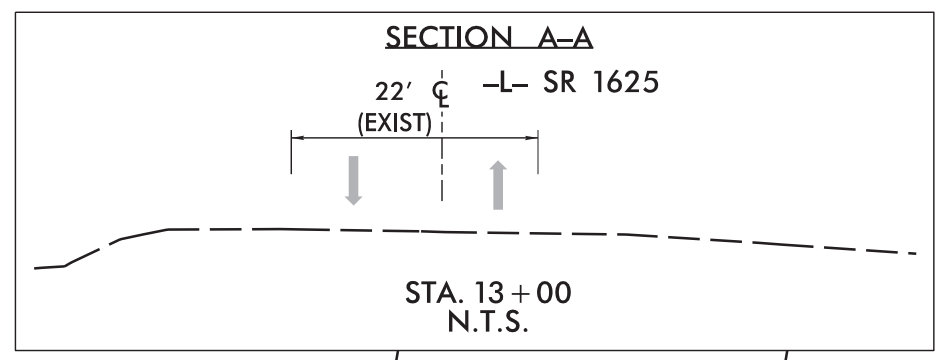

APPROVED: *William C. Carver*
DATE: 08/15/2023

DocuSigned by:
103525A8510349F

SEAL

**DOCUMENT NOT CONSIDERED FINAL
UNLESS ALL SIGNATURES COMPLETED**



PHASE I DETAIL

7/24/2023
S:\DGC\Projects\Burke\NR-5967\Tr\of\ic\TCP\NR-5967_dde-TC_TMP-TMP3.dgn
User:htfletcher

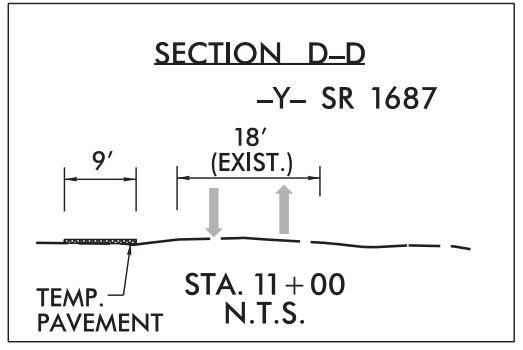

*INSTALL 300LF OF 15" DRAINAGE PIPE BETWEEN -Y- STA. 10+50 TO -Y- STA. 13+50 OR AS DIRECTED BY THE ENGINEER.

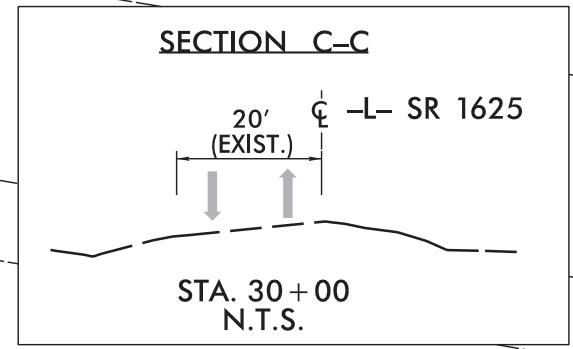

MATCHLINE -L- STA 23+50 SEE SHEET TMP-3

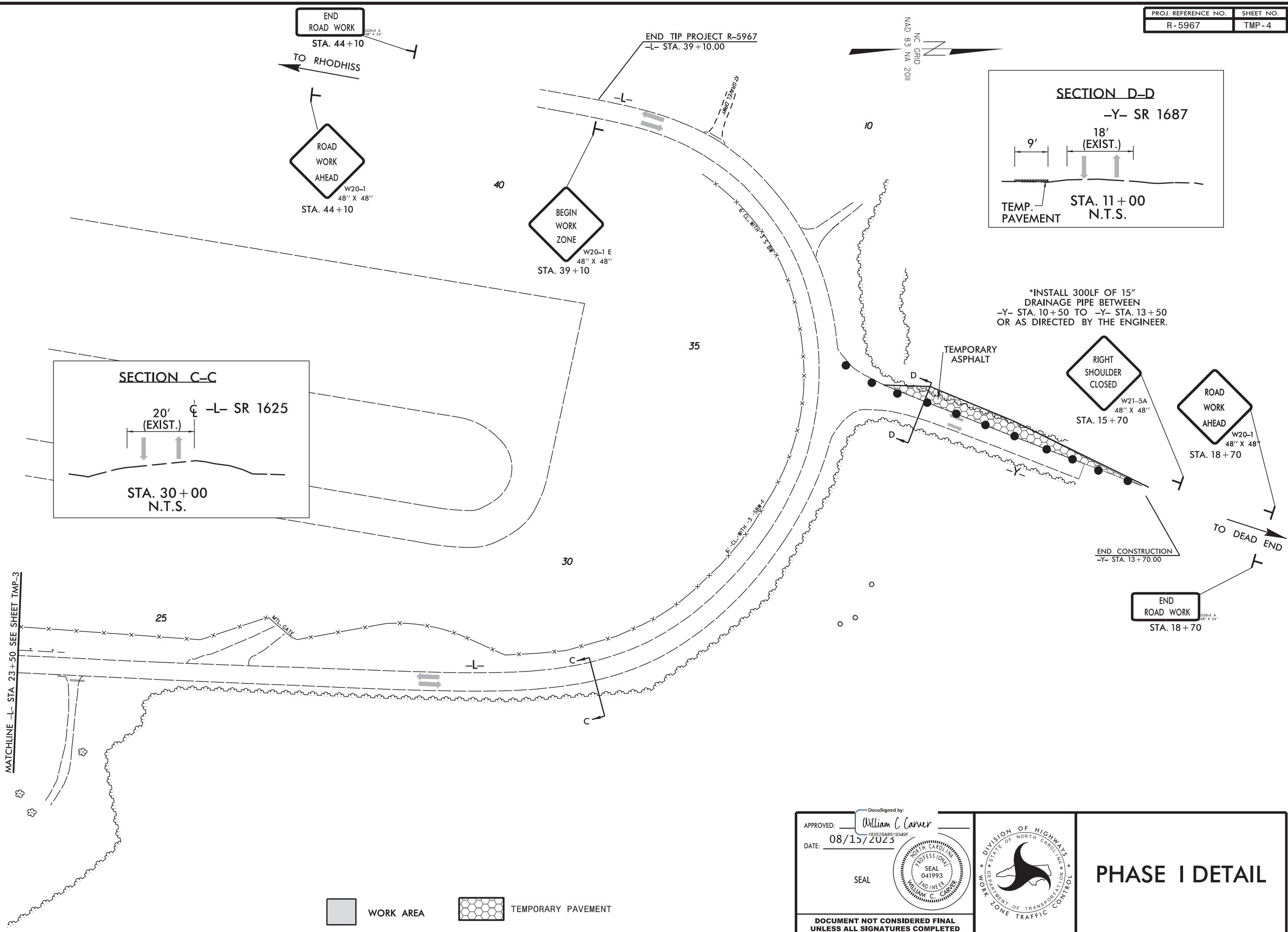

7/24/2023
S:\D00\Projects\Burke\NR-5967\Trcf\TC\NA\R-5967_dde.tc.tmp_tmp4.dgn
User:htfletcher

DocuSigned by:
APPROVED: *William C. Carver*
DATE: 08/15/2023

SEAL

**DOCUMENT NOT CONSIDERED FINAL
UNLESS ALL SIGNATURES COMPLETED**

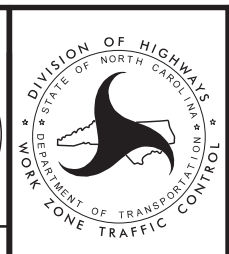

PHASE I DETAIL

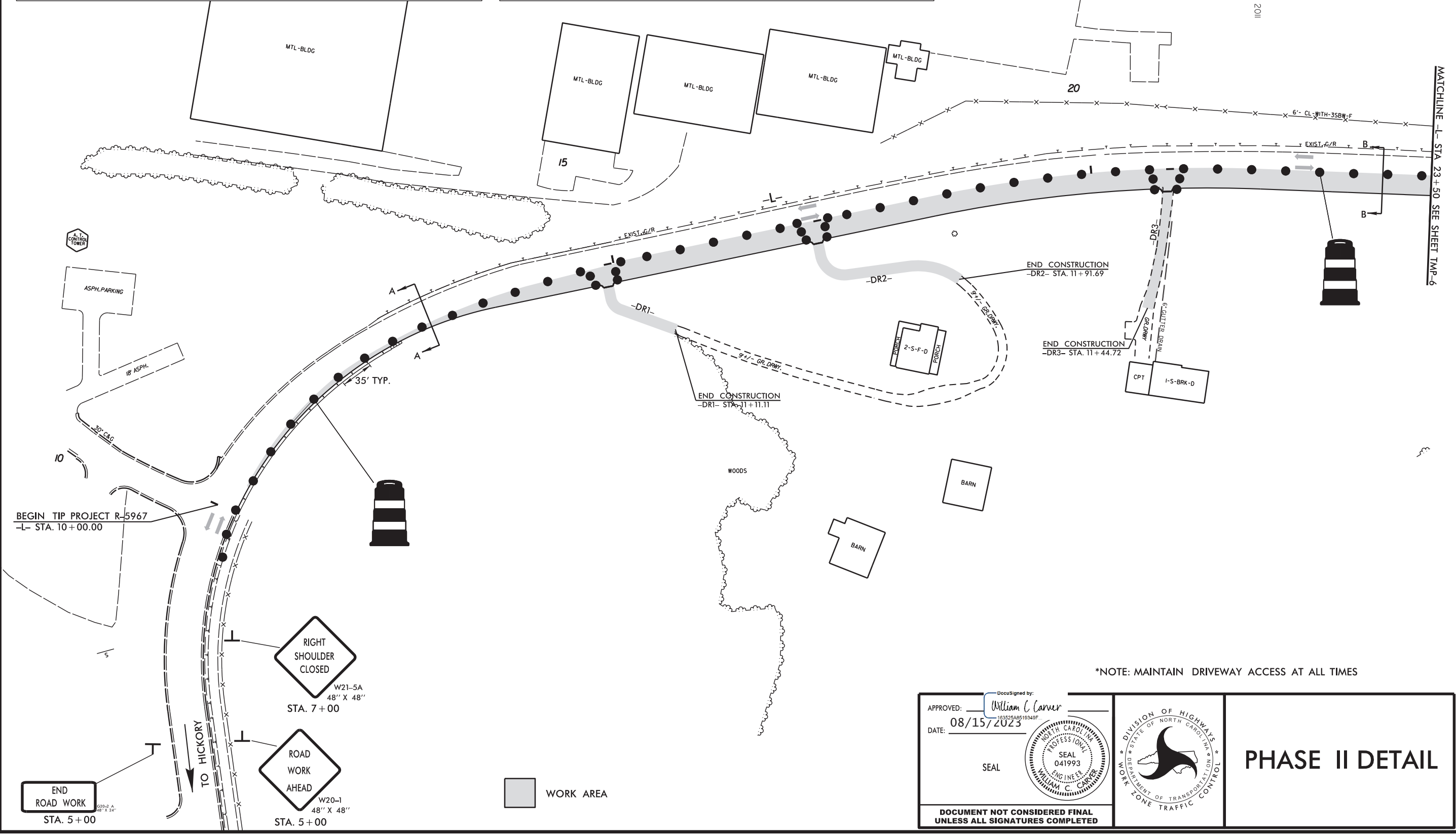
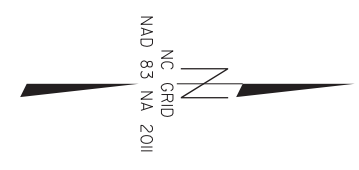
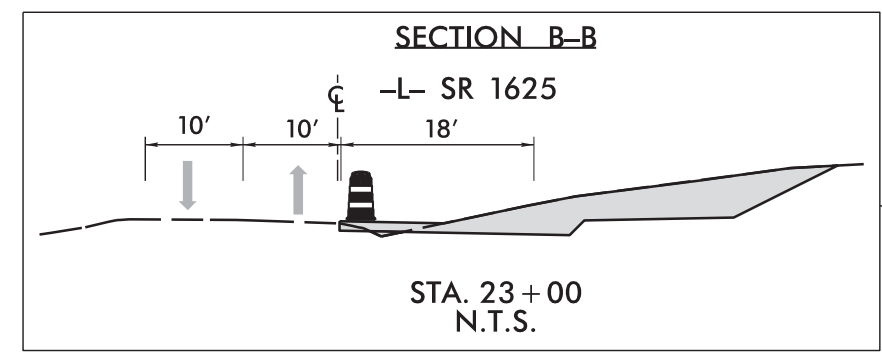
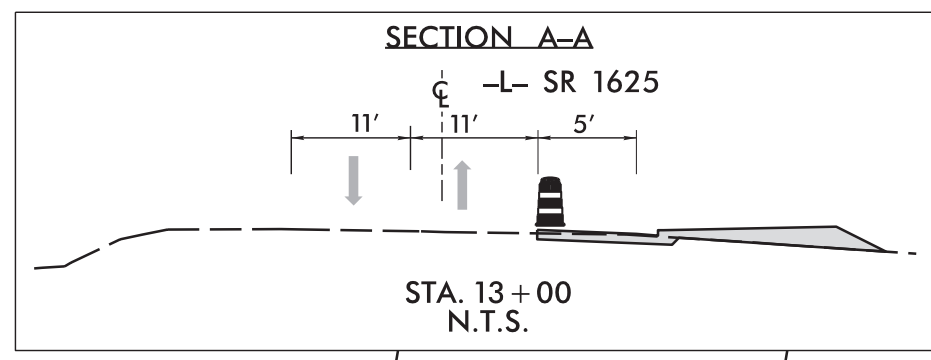

BEGIN TIP PROJECT R-5967
-L- STA. 10+00.00

END ROAD WORK
STA. 5+00

RIGHT SHOULDER CLOSED
W21-5A
48" X 48"
STA. 7+00

ROAD WORK AHEAD
W20-1
48" X 48"
STA. 5+00

WORK AREA

*NOTE: MAINTAIN DRIVEWAY ACCESS AT ALL TIMES

APPROVED: *William C. Carver*
DATE: 08/15/2023
SEAL
DOCUMENT NOT CONSIDERED FINAL
UNLESS ALL SIGNATURES COMPLETED

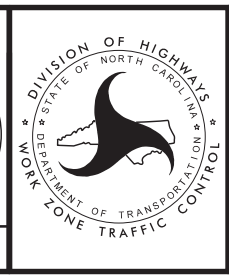

PHASE II DETAIL

7/24/2023 S:\DCC\Projects\Burke\NR-5967\Tr\of\ic\TCP\NR-5967_ddc_TC_TMP_TMP5.dgn User:ttfletcher

NAD 83 NA 2011

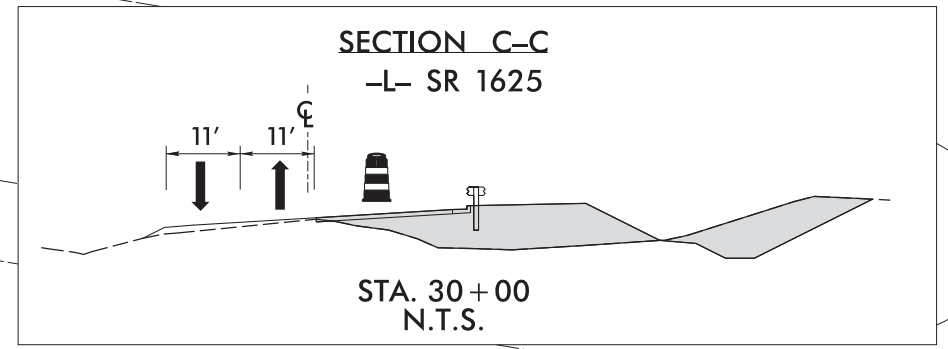
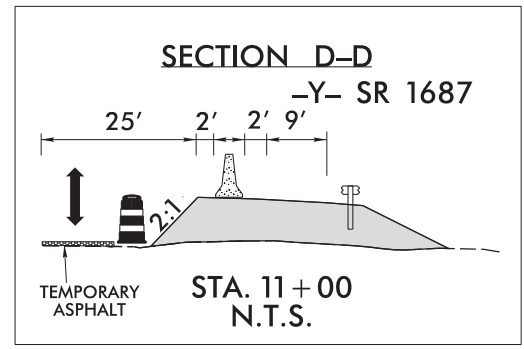

MATCHLINE -L- STA 23+50 SEE SHEET TMP-5

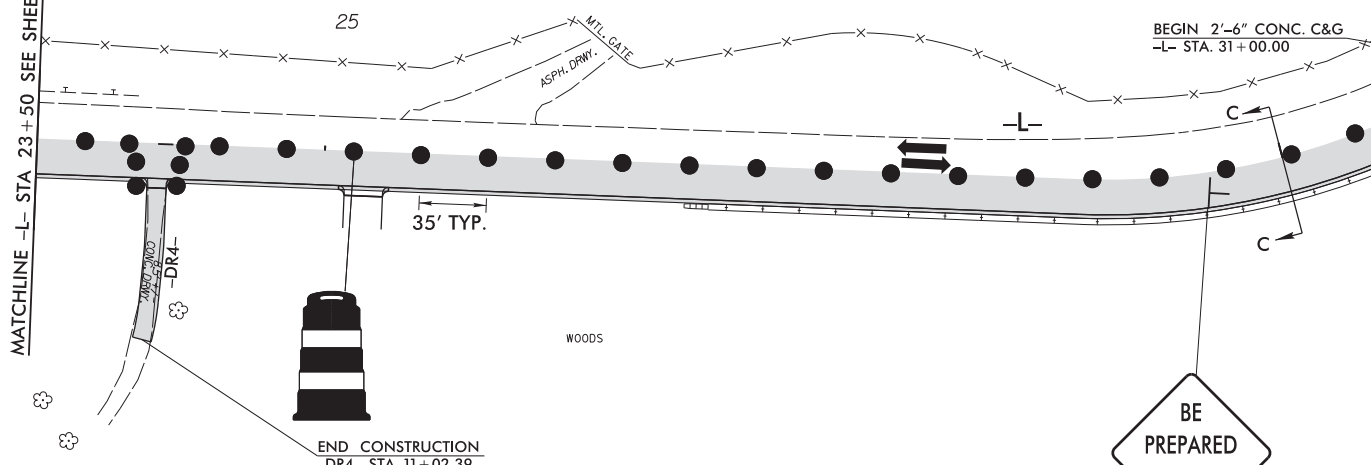

END ROAD WORK STA. 44+10
 END TIP PROJECT R-5967 -L- STA. 39+10.00
 TO RHODHISS

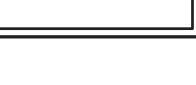
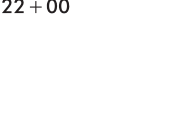
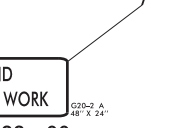
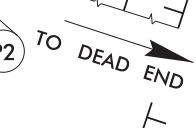
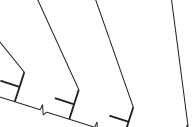
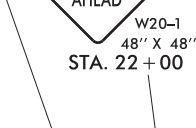
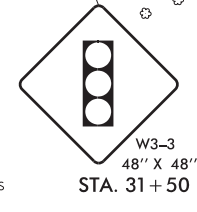
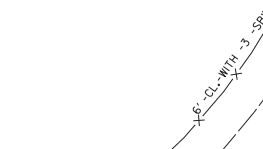
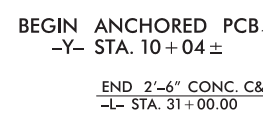
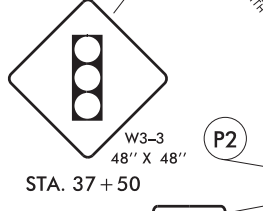
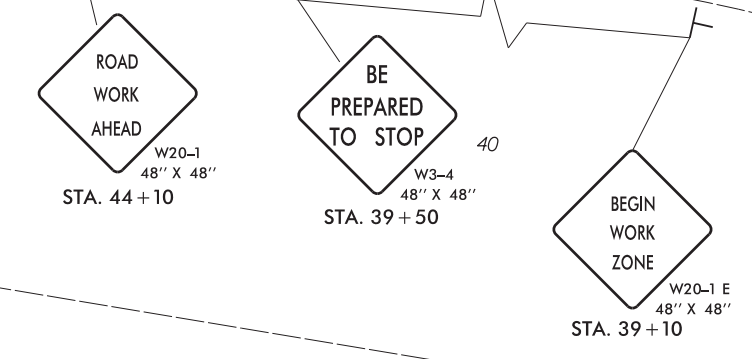

WORK AREA
 TEMPORARY PAVEMENT

-ENDANGERED SPECIES BUFFER ZONE

APPROVED: *William C. Carver*
 DATE: 08/28/2023
 SEAL
 DOCUMENT NOT CONSIDERED FINAL UNLESS ALL SIGNATURES COMPLETED

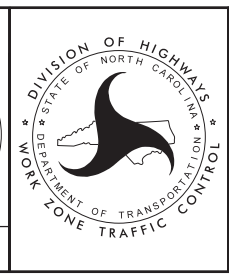

PHASE II DETAIL

28-AUG-2023 10:42
 S:\DDC\Projects\Burke\5967\Traf\TC\TPAR-5967-ddc-TC-TMP-TMP6.dgn
 \$\$\$USERNAME\$\$\$

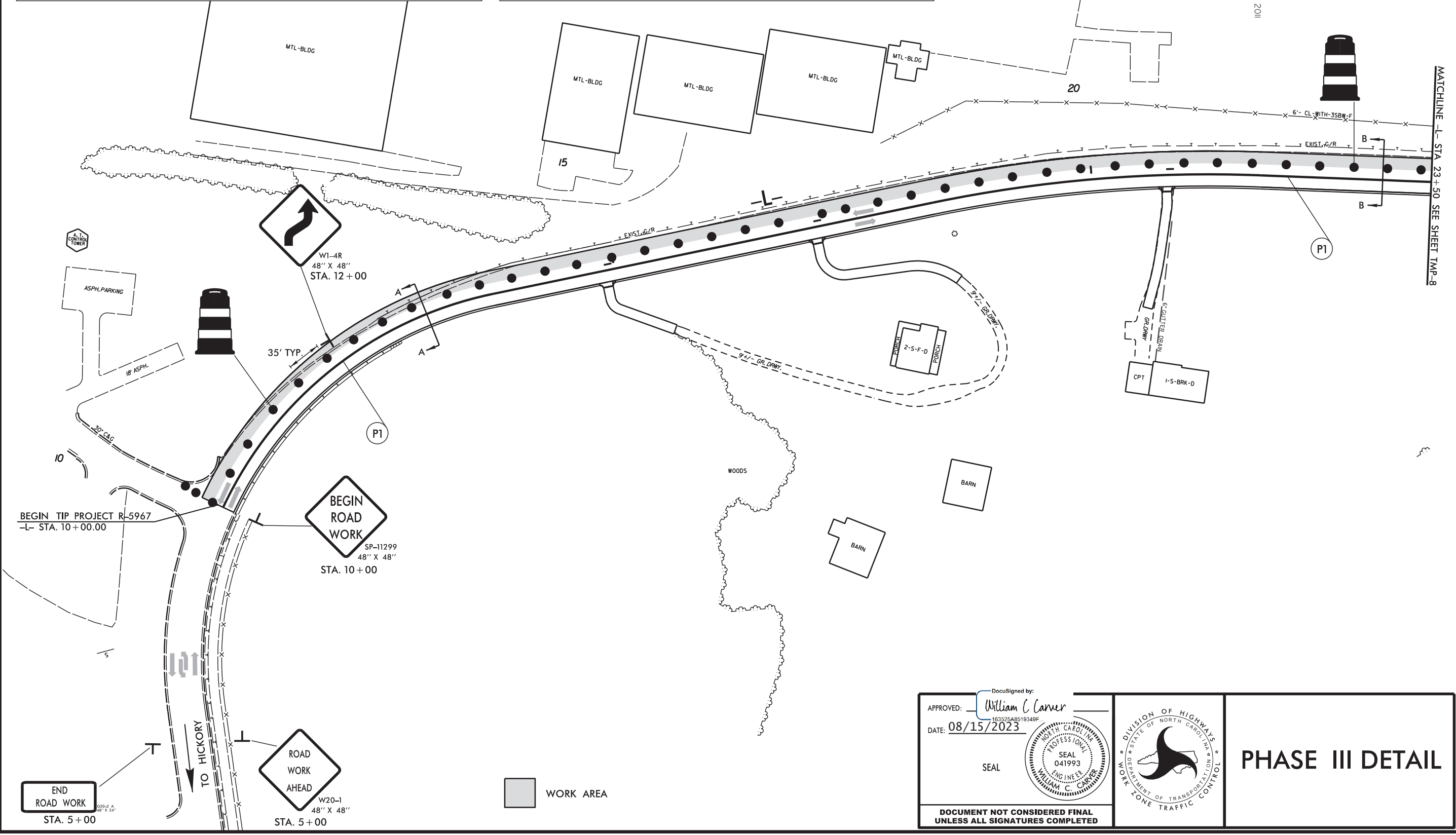
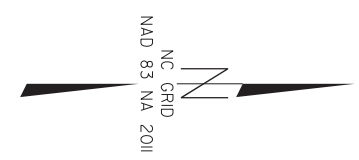
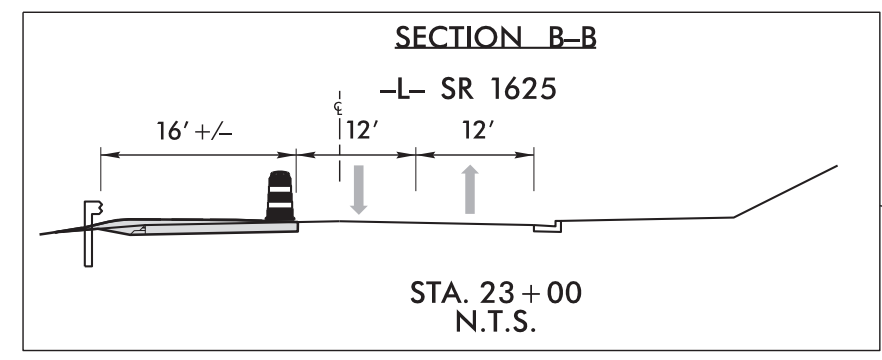
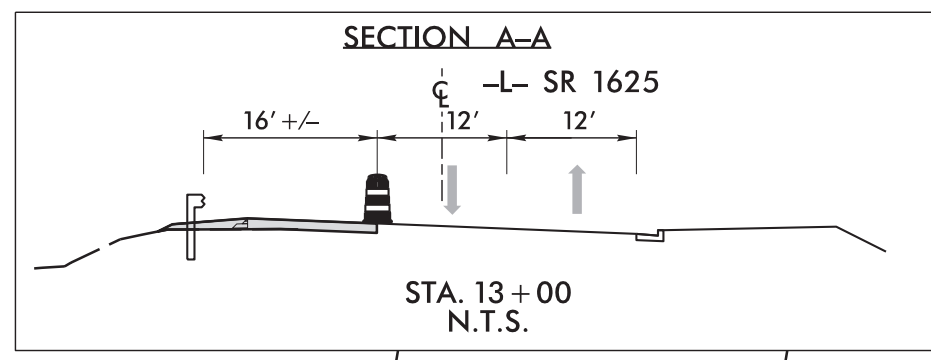

BEGIN TIP PROJECT R-5967
-L- STA. 10+00.00

BEGIN ROAD WORK
SP-11299
48" X 48"
STA. 10+00

END ROAD WORK
STA. 5+00

ROAD WORK AHEAD
W20-1
48" X 48"
STA. 5+00

WORK AREA

APPROVED: *William C. Carver*
DATE: 08/15/2023
SEAL
DOCUMENT NOT CONSIDERED FINAL
UNLESS ALL SIGNATURES COMPLETED



PHASE III DETAIL

7/28/2023 S:\DCC\Projects\Burke\NR-5967\Tr\of\ic\TCP\NR-5967_ddc_TC_TMP_TMP7.dgn User:htfletcher

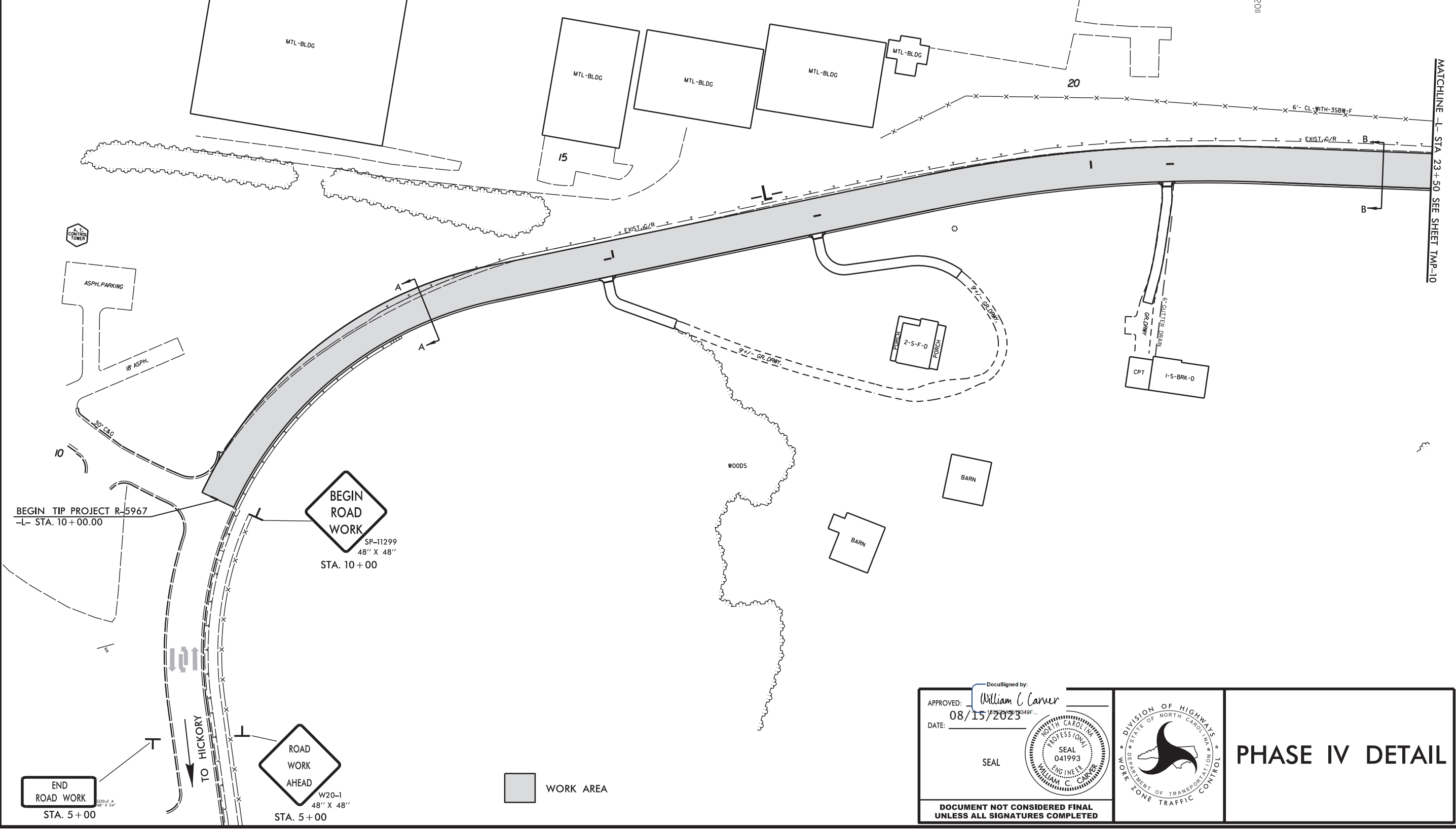
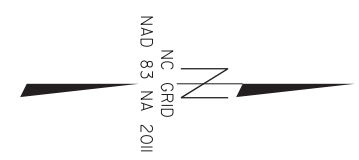
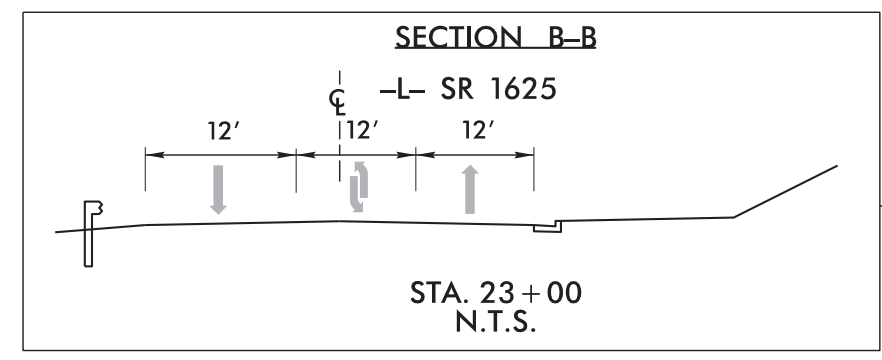
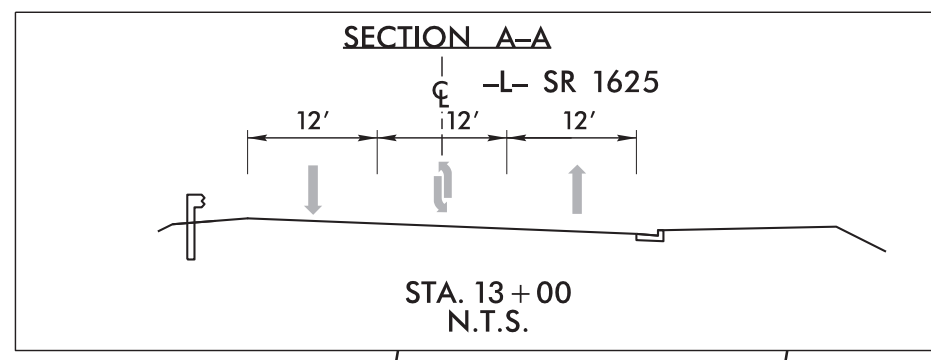

BEGIN TIP PROJECT R-5967
-L- STA. 10+00.00

BEGIN ROAD WORK
SP-11299
48" X 48"
STA. 10+00

END ROAD WORK
STA. 5+00

ROAD WORK AHEAD
W20-1
48" X 48"
STA. 5+00

WORK AREA

APPROVED: *William C. Carver*
DATE: 08/15/2023
SEAL

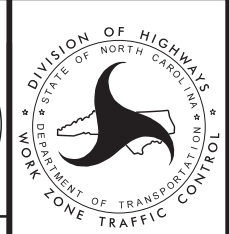
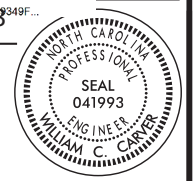

PHASE IV DETAIL

DOCUMENT NOT CONSIDERED FINAL
UNLESS ALL SIGNATURES COMPLETED

7/28/2023 S:\DCC\Projects\Burke\NR-5967\Tr\of\ic\TCP\NR-5967_ddc_TC_TMP_TMP9.dgn User:htfletcher

NAD 83 NA 2011
NC GRID

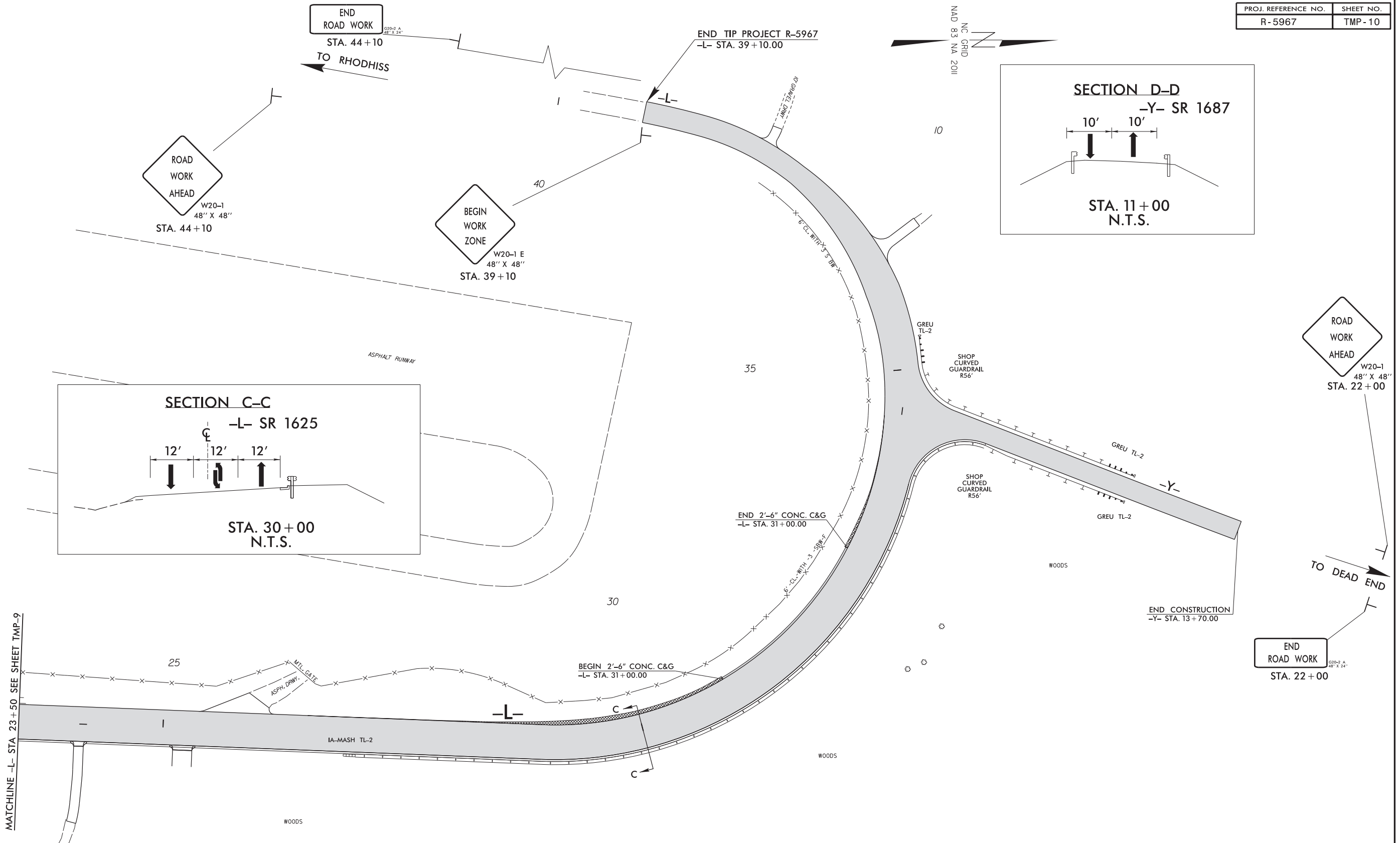
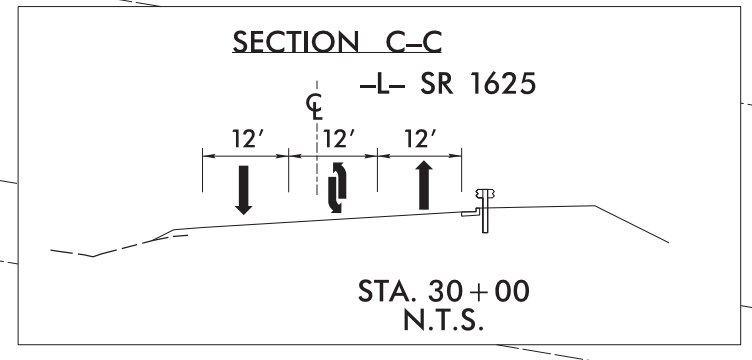
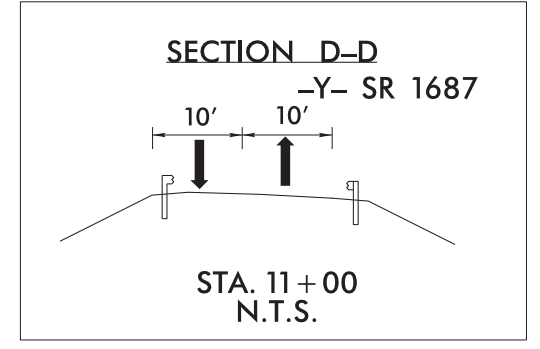

28-AUG-2023 10:45
 S:\DDC\Projects\Burke\ke\NR-5967\Tr\of\fig\TCP\NR-5967_ddc_TC_TMP_TMP10.dgn
 \$\$\$USERNAME\$\$\$



-ENDANGERED SPECIES BUFFER ZONE

DocuSigned by:
 APPROVED: *William C. Carver*
 DATE: 08/28/2023
 SEAL
 DOCUMENT NOT CONSIDERED FINAL
 UNLESS ALL SIGNATURES COMPLETED



 DIVISION OF HIGHWAYS
 STATE OF NORTH CAROLINA
 DEPARTMENT OF TRANSPORTATION
 WORK ZONE TRAFFIC CONTROL
PHASE IV DETAIL

STATE OF NORTH CAROLINA
DIVISION OF HIGHWAYS

TIP NO. R-5967	SHEET NO. PMP-1
Approved by:  DATE: 11/14/2023	
SEAL 	

PAVEMENT MARKING PLAN BURKE COUNTY

ROADWAY STANDARD DRAWINGS

THE FOLLOWING ROADWAY STANDARDS AS APPEAR IN "ROADWAY STANDARD DRAWINGS" PROJECT SERVICES UNIT - N.C. DEPARTMENT OF TRANSPORTATION - RALEIGH, N.C., DATE JANUARY 2024 ARE APPLICABLE TO THIS PROJECT AND BY REFERENCE HEREBY ARE CONSIDERED A PART OF THESE PLANS:

STD. NO.	TITLE
1205.01	PAVEMENT MARKINGS - LINE TYPES AND OFFSETS
1205.02	PAVEMENT MARKINGS - TWO-LANE AND MULTILANE ROADS
1205.04	PAVEMENT MARKINGS - INTERSECTIONS
1205.05	PAVEMENT MARKINGS - TURN LANES
1205.08	PAVEMENT MARKINGS - SYMBOLS AND WORD MESSAGES
1205.09	PAVEMENT MARKINGS - PAINTED ISLANDS
1250.01	RAISED PAVEMENT MARKERS - INSTALLATION SPACING
1261.01	GUARDRAIL AND BARRIER DELINEATORS - INSTALLATION SPACING
1261.02	GUARDRAIL AND BARRIER DELINEATORS - TYPES AND MOUNTING
1262.01	GUARDRAIL END DELINEATION

GENERAL NOTES

THE FOLLOWING GENERAL NOTES APPLY AT ALL TIMES FOR THE DURATION OF THE CONSTRUCTION PROJECT, EXCEPT WHEN OTHERWISE NOTED IN THE PLAN, OR DIRECTED BY THE ENGINEER.

A) INSTALL PAVEMENT MARKINGS AND PAVEMENT MARKERS ON THE FINAL SURFACE AS FOLLOWS:

ROAD NAME	MARKING	MARKER
SR 1625 (9TH AVE DR NW) (-L-)	THERMOPLASTIC	SNOWPLOWABLE RAISED
SR 1687 (GOAT FARM ST.) (-Y-)	THERMOPLASTIC	NONE

USE THERMOPLASTICS FOR STOP BARS, SYMBOLS, CHARACTERS, AND DIAGONALS ALL ROADS.

B) TIE PROPOSED PAVEMENT MARKINGS LINES TO EXISTING PAVEMENT MARKING LINES.

C) REMOVE/REPLACE ANY CONFLICTING/DAMAGED PAVEMENT MARKINGS AND MARKERS.

D) STOP BAR LOCATION AT NON-SIGNALIZED INTERSECTIONS MAY BE ADJUSTED AS DIRECTED BY THE ENGINEER.

E) REMOVE ALL RESIDUE AND SURFACE LAITANCE BY ACCEPTABLE METHODS ON CONCRETE BRIDGE DECKS PRIOR TO PLACING PAVEMENT MARKING MATERIAL. IN ACCORDANCE WITH APPROVED METHODS AND THE 2024 STANDARD SPECIFICATIONS FOR ROADS AND STRUCTURES, THE CONTRACTOR SHALL REMOVE CURING COMPOUND FROM ALL OTHER CONCRETE SURFACES PRIOR TO PLACING FINAL PAVEMENT MARKING MATERIAL.

F) UNLESS OTHERWISE SPECIFIED, HEATED-IN-PLACE THERMOPLASTIC MAY BE USED IN LIEU OF EXTRUDED THERMOPLASTIC FOR STOP BARS, SYMBOLS, CHARACTERS, AND DIAGONALS. IF HEATED-IN-PLACED IS USED, IT SHALL BE PAID FOR USING THE EXTRUDED THERMOPLASTIC PAY ITEM.

INDEX

SHEET NO.	DESCRIPTION
PMP-1	PAVEMENT MARKING PLAN TITLE, INDEX OF SHEETS, LIST OF APPLICABLE ROADWAY STANDARD DRAWINGS, GENERAL NOTES, AND FINAL PAVEMENT MARKING SCHEDULE
PMP-2	PAVEMENT MARKING PLAN
PMP-3	PAVEMENT MARKING PLAN

FINAL PAVEMENT MARKING SCHEDULE

PAVEMENT MARKINGS		PAVEMENT MARKINGS	
THERMOPLASTICS (24", 90 MILS)		THERMOPLASTIC PAVEMENT MARKING SYMBOLS (90 MILS)	
T61	WHITE STOP	T70	LEFT TURN ARROW
		T71	RIGHT TURN ARROW
		T75	LEFT/RIGHT TURN ARROW
THERMOPLASTIC (4")		SNOWPLOWABLE RAISED PAVEMENT MARKERS	
T1	WHITE EDGELINE	ME	YELLOW & YELLOW
T2	WHITE SOLID LANE LINE	MF	CRYSTAL & RED
T3	10 FT. WHITE SKIP		
T4	3 T. - 9FT/SP WHITE MINISKIP		
T12	10 FT. YELLOW SKIP		
T11	YELLOW SINGLE CENTER		
T13	YELLOW DOUBLE CENTER		

TIP NO. R-5967	SHEET NO. PMP-2
APPROVED: <i>William C. Carver</i>	
DATE: 10/26/2023	
SEAL	
DOCUMENT NOT CONSIDERED FINAL UNLESS ALL SIGNATURES COMPLETED	

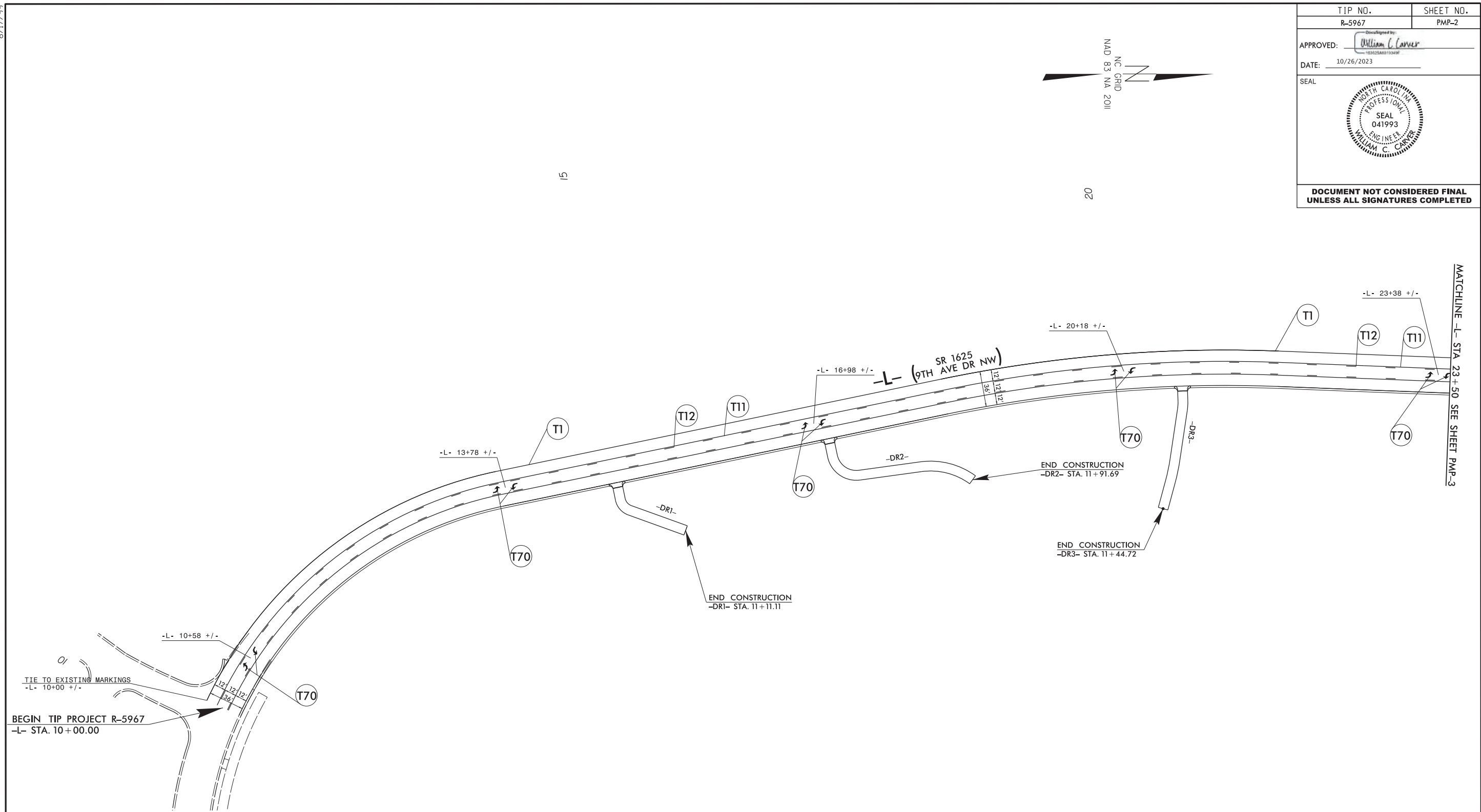
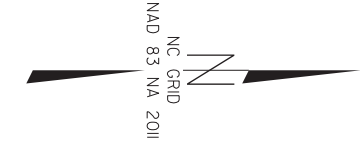

PROJECT NOTES

- SEE SHEET PMP-1 FOR FINAL PAVEMENT MARKING SCHEDULE
- SEE NCDOT 2024 STANDARD DRAWING 1205.02 FOR CONTINUOUS LEFT TURN LANE SYMBOLS.
- CONTINUOUS LEFT TURN LANE SYMBOLS SHOULD BE PLACED AT 320' SPACING.
- SEE NCDOT 2024 STANDARD DRAWING 1250.01 FOR PLACEMENT OF MARKERS (ME) AND (MF).

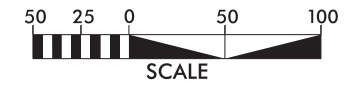

8/17/99
 26-OCT-2023 09:59
 S:\DDC\Projects\Bur-ke\R-5967\Traffic\SR1625\967_ddc_pmp-2.dgn
 \$\$\$USERNAME\$\$\$

PROJECT NOTES

- SEE SHEET PMP-1 FOR FINAL PAVEMENT MARKING SCHEDULE
- SEE NCDOT 2024 STANDARD DRAWING 1205.02 FOR CONTINUOUS LEFT TURN LANE SYMBOLS.
- CONTINUOUS LEFT TURN LANE SYMBOLS SHOULD BE PLACED AT 320' SPACING.
- SEE NCDOT 2024 STANDARD DRAWING 1250.01 FOR PLACEMENT OF MARKERS (ME) AND (MF).

TIP NO. R-5967	SHEET NO. PMP-3
APPROVED: <i>William C. Carver</i>	
DATE: 10/26/2023	
SEAL 	
DOCUMENT NOT CONSIDERED FINAL UNLESS ALL SIGNATURES COMPLETED	

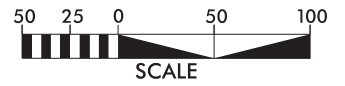
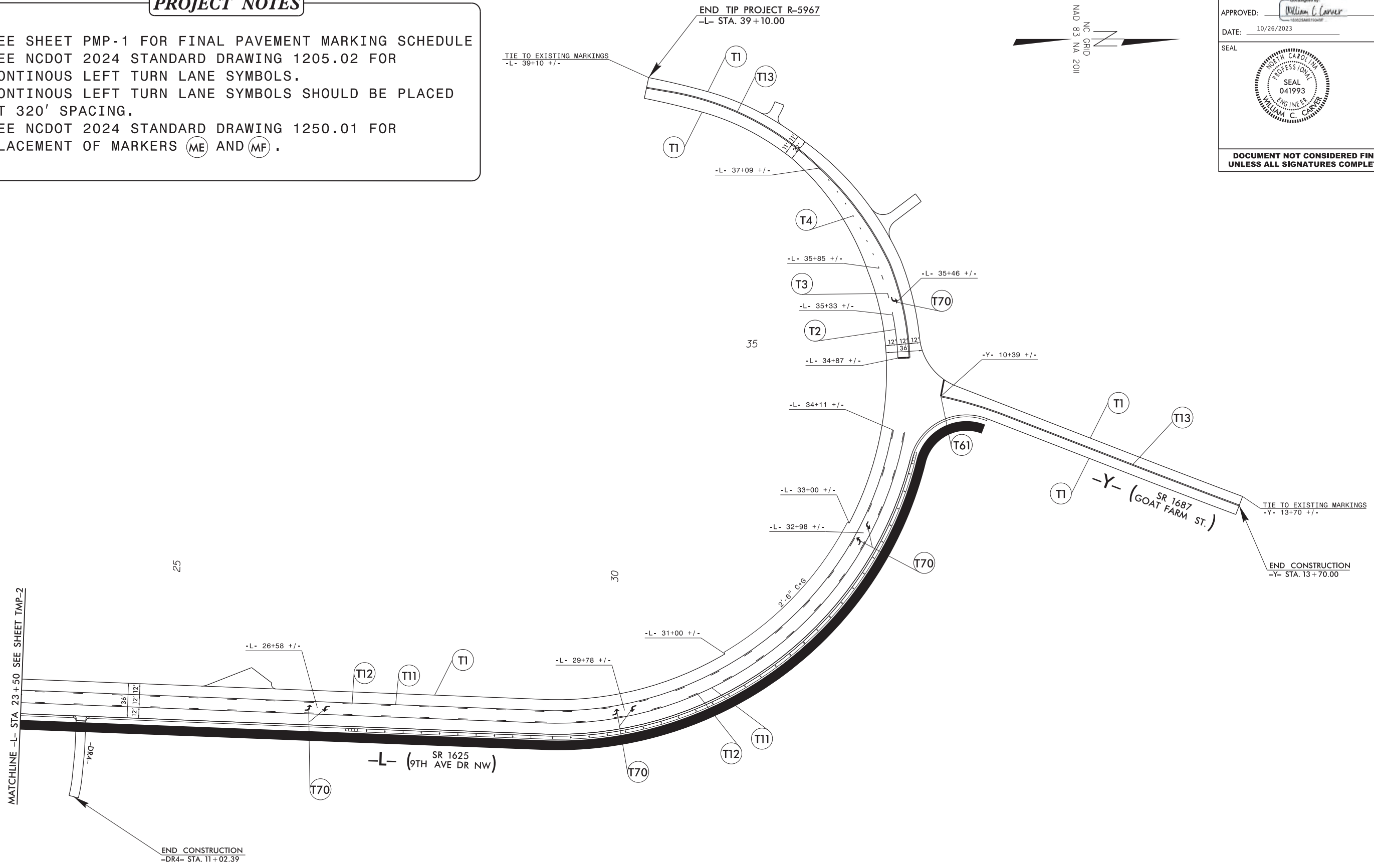

26-OCT-2023 10:00
 S:\DDC\Projects\Bur-ke\R-5967\Traffic\R5967_ddc_pmp-3.dgn
 \$\$\$\$USFRNAME\$\$\$

TIP PROJECT: R-5967

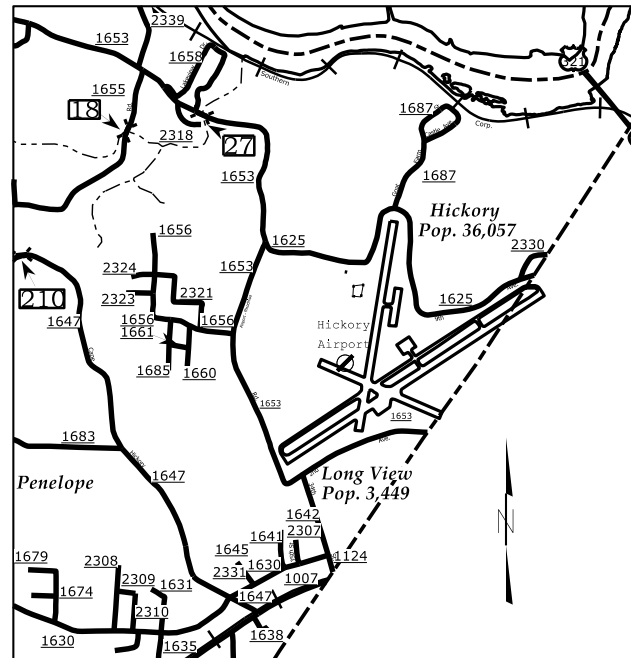

STATE OF NORTH CAROLINA
DIVISION OF HIGHWAYS
**PLAN FOR PROPOSED
HIGHWAY EROSION CONTROL
BURKE COUNTY**

LOCATION: SR 1625 (9TH AVE DR NW)

TYPE OF WORK: WIDENING, MILLING, PAVING, PAVEMENT MARKING
AND DRAINAGE

END TIP PROJECT R-5967
-L- STA 39+00.00

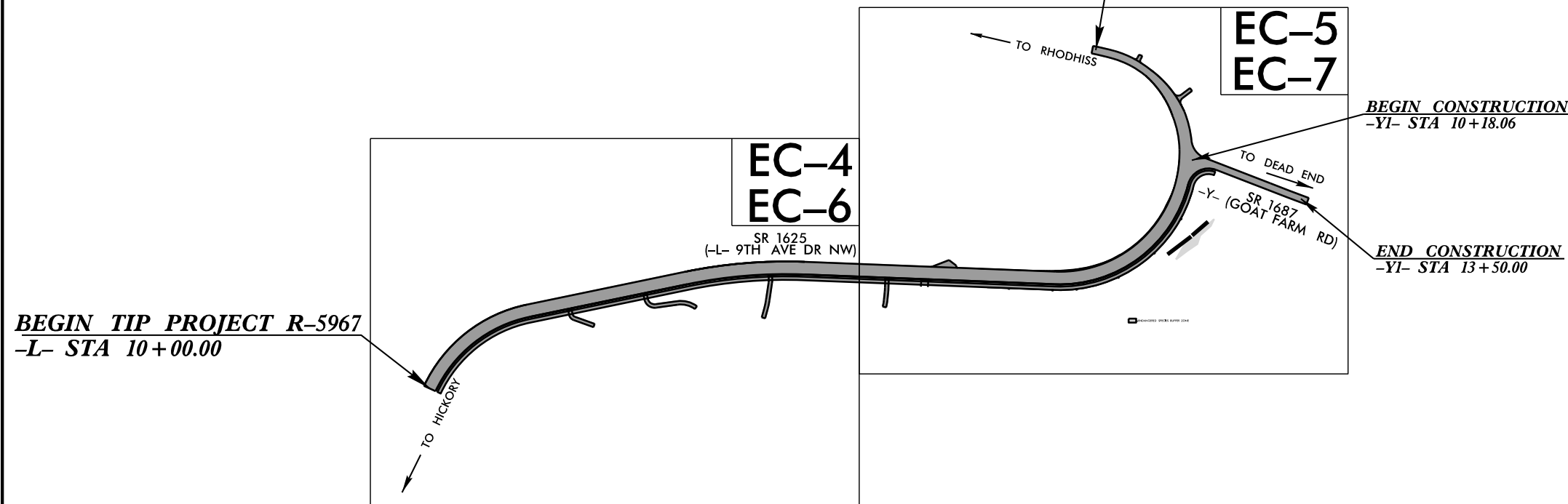

EROSION AND SEDIMENT CONTROL MEASURES

Std. #	Description	Symbol
1630.03	Temporary Silt Ditch	TD
1630.05	Temporary Diversion	TD
1605.01	Temporary Silt Fence	
1606.01	Special Sediment Control Fence	
1622.01	Temporary Berms and Slope Drains	TD
1630.02	Silt Basin Type B	SB
1633.01	Temporary Rock Silt Check Type-A	RS
	Temporary Rock Silt Check Type-A with Matting and Polyacrylamide (PAM)	RS
1633.02	Temporary Rock Silt Check Type-B	RS
	Wattle/Coir Fiber Wattle	W
	Wattle/Coir Fiber Wattle with Polyacrylamide (PAM)	W
1634.01	Temporary Rock Sediment Dam Type-A	RD
1634.02	Temporary Rock Sediment Dam Type-B	RD
1635.01	Rock Pipe Inlet Sediment Trap Type-A	RPI
1635.02	Rock Pipe Inlet Sediment Trap Type-B	RPI
1630.04	Stilling Basin	SB
1630.06	Special Stilling Basin	SB
	Rock Inlet Sediment Trap:	
1632.01	Type A	A
1632.02	Type B	B
1632.03	Type C	C
	Skimmer Basin	SK
	Tiered Skimmer Basin	SK
	Infiltration Basin	IB

THIS PROJECT CONTAINS
EROSION CONTROL PLANS
FOR CLEARING AND
GRUBBING PHASE OF
CONSTRUCTION.

GRAPHIC SCALE

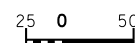

PLANS

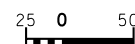

PROFILE (HORIZONTAL)

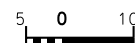

PROFILE (VERTICAL)

THESE EROSION AND SEDIMENT CONTROL
PLANS COMPLY WITH THE REGULATIONS SET
FORTH BY THE NCG-010000 GENERAL
CONSTRUCTION PERMIT EFFECTIVE
APRIL 1, 2019 ISSUED BY THE NORTH
CAROLINA DEPARTMENT OF ENVIRONMENT
AND NATURAL RESOURCES DIVISION
OF WATER QUALITY.

Prepared In the Office of:
DIVISION 13 DDC
55 Orange St.
Asheville, NC 28801

2024 STANDARD SPECIFICATIONS

Designed by:

Hampton Fletcher
NAME

3382

LEVEL III CERTIFICATION NO.

Reviewed In the Office of:
ROADSIDE ENVIROMENTAL UNIT
693 Mountain Rd.
Hendersonville, NC 28791

2024 STANDARD SPECIFICATIONS

Reviewed by:

Reid Whitehead PE, CPESC
NAME

Roadway Standard Drawings

The following roadway english standards as appear in "Roadway Standard Drawings"- Roadway Design Unit - N. C. Department of Transportation - Raleigh, N. C., dated January 2024 and the latest revision thereto are applicable to this project and by reference hereby are considered a part of these plans.

1605.01 Temporary Silt Fence	1632.03 Rock Inlet Sediment Trap Type C
1606.01 Special Sediment Control Fence	1633.01 Temporary Rock Silt Check Type A
1607.01 Gravel Construction Entrance	1636.01 Wattle Check
1622.01 Temporary Berms and Slope Drains	1640.01 Coir Fiber Jaffle
1630.02 Silt Basin Type B	
1630.03 Temporary Silt Ditch	
1630.07 Skimmer Basin with Jaffles	
1631.01 Matting Installation	

DIVISION OF HIGHWAYS
STATE OF NORTH CAROLINA

PROJECT REFERENCE NO. <i>R-5967</i>	SHEET NO. <i>EC-3A</i>
ROADWAY DESIGN ENGINEER	HYDRAULICS ENGINEER

SOIL STABILIZATION TIMEFRAMES

<i>SITE DESCRIPTION</i>	<i>STABILIZATION TIME</i>	<i>TIMEFRAME EXCEPTIONS</i>
PERIMETER DIKES, SWALES, DITCHES AND SLOPES	7 DAYS	NONE
HIGH QUALITY WATER (HQW) ZONES	7 DAYS	NONE
SLOPES STEEPER THAN 3:1	7 DAYS	IF SLOPES ARE 10' OR LESS IN LENGTH AND ARE NOT STEEPER THAN 2:1, 14 DAYS ARE ALLOWED.
SLOPES 3:1 OR FLATTER	14 DAYS	7 DAYS FOR SLOPES GREATER THAN 50' IN LENGTH.
ALL OTHER AREAS WITH SLOPES FLATTER THAN 4:1	14 DAYS	NONE, EXCEPT FOR PERIMETERS AND HQW ZONES.

PROJECT REFERENCE NO.	SHEET NO.
R-5967	EC-4
RW SHEET NO.	
ROADWAY DESIGN ENGINEER	HYDRAULICS ENGINEER
DOCUMENT NOT CONSIDERED FINAL UNLESS ALL SIGNATURES COMPLETED	

8/17/99

REVISIONS



BEGIN TIP PROJECT R-5967
-L- STA. 10+00.00

BEGIN 10' MULTI-USE PATH
-L- STA. 10+00.00

BEGIN 2'-6" CONC. C&G
-L- STA. 10+00.00

CLEARING AND GRUBBING
EROSION CONTROL FOR
CONSTRUCTION SHEET 4

15-AUG-2023 15:16 Burke R-5967 Environmental\Design\R-5967_EC_ddc_psh4_CG.dgn
 S:\06\Projects\1513330171\1513330171.dwg
 Mccarver

8/17/99
 REVISIONS
 15-AUG-2023 J547
 S:\06\Projects\0613330171\Bucke\AR-5967\Environmental\Design\AR-5967_EC_ddc_psh5_CG.dgn
 Mccoy

-L-		-Y-	
PI Sta 32+81.63	PI Sta 37+23.74	PI Sta 10+57.65	PI Sta 13+11.36
$\Delta = 94' 15" 02.6" (LT)$	$\Delta = 78' 17" 49.1" (LT)$	$\Delta = 13' 51" 13.0" (RT)$	$\Delta = 0' 41" 00.0" (LT)$
D = 15' 54" 55.8"	D = 19' 37" 34.3"	D = 13' 03" 12.2"	D = 0' 34" 10.0"
L = 592.19'	L = 398.94'	L = 106.13'	L = 120.00'
T = 387.75'	T = 237.66'	T = 53.33'	T = 60.00'
R = 360.00'	R = 291.94'	R = 438.93'	R = 10,061.58'
DS = 45	DS = 45		
SE = 0.06	SE = 0.06		

-DR4-	
PI Sta 10+53.41	PI Sta 11+16.97
$\Delta = 3' 28" 55.0" (RT)$	$\Delta = 30' 54" 10.6" (RT)$
D = 28' 38" 52.4"	D = 45' 49" 10.9"
L = 12.15'	L = 67.44'
T = 6.08'	T = 34.56'
R = 200.00'	R = 125.05'

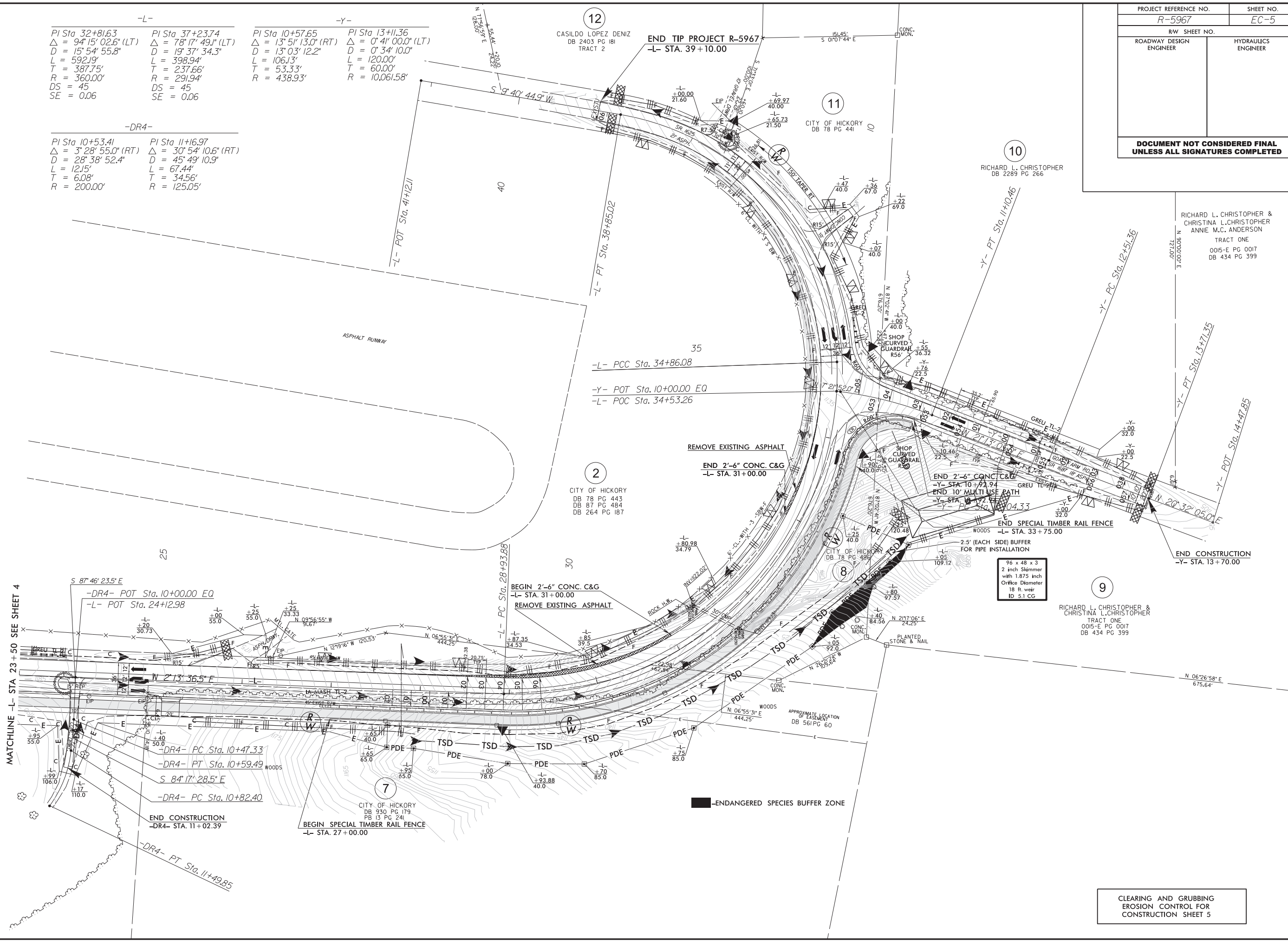

PROJECT REFERENCE NO. R-5967	SHEET NO. EC-5
RW SHEET NO.	
ROADWAY DESIGN ENGINEER	HYDRAULICS ENGINEER
DOCUMENT NOT CONSIDERED FINAL UNLESS ALL SIGNATURES COMPLETED	

RICHARD L. CHRISTOPHER &
 CHRISTINA L. CHRISTOPHER
 ANNIE M.C. ANDERSON
 TRACT ONE
 0015-E PG 0017
 DB 434 PG 399

RICHARD L. CHRISTOPHER &
 CHRISTINA L. CHRISTOPHER
 TRACT ONE
 0015-E PG 0017
 DB 434 PG 399

CLEARING AND GRUBBING
 EROSION CONTROL FOR
 CONSTRUCTION SHEET 5

PROJECT REFERENCE NO.	SHEET NO.
R-5967	EC-6
RW SHEET NO.	
ROADWAY DESIGN ENGINEER	HYDRAULICS ENGINEER
DOCUMENT NOT CONSIDERED FINAL UNLESS ALL SIGNATURES COMPLETED	

8/17/99

REVISIONS

15-AUG-2023 15:19
S:\06\Projects\Bucke\R-5967\Environmental\Design\R-5967_EC_ddc_psh6_f inal.dgn
M:\13-33071
Mccarver



2
CITY OF HICKORY
DB 78 PG 443
DB 87 PG 484
DB 264 PG 187

3
DB 932 PG 756
DB 486 PG 458
PB 13 PG 242

1
CITY OF HICKORY
DB 486 PG 458

4
CITY OF HICKORY
DB 930 PG 179
PB 13 PG 241

6
STEPHEN WAYNE WINKLER
DB 777 PG 565
20E PG 291

5
CATHERINE K. WINKLER
DB 2585 PG 480
PARCEL I
PARCEL II
PARCEL III

2
CITY OF HICKORY
DB 78 PG 443
DB 87 PG 484
DB 264 PG 187

MATCHLINE -L- STA 23+50 SEE SHEET 4

STATE OF NORTH CAROLINA
DIVISION OF HIGHWAYS

**SIGNING PLAN
BURKE COUNTY**

LOCATION: SR 1625 (9TH AVE DR NW)

TIP NO. R-5967	SHEET NO. SIGN-1
APPROVED: <i>William C. Carver</i> 10352548519348F	
DATE: 10/17/2023	
SEAL	



ROADWAY STANDARD DRAWINGS

THE FOLLOWING ROADWAY STANDARDS AS APPEAR IN "ROADWAY STANDARD DRAWINGS" PROJECT SERVICES UNIT - N.C. DEPARTMENT OF TRANSPORTATION - RALEIGH, N.C., DATE JANUARY 2024 ARE APPLICABLE TO THIS PROJECT AND BY REFERENCE HEREBY ARE CONSIDERED A PART OF THESE PLANS:

STD. NO.	TITLE
904.1	ORIENTATION OF GROUND MOUNTED SIGNS
904.5	MOUNTING OF TYPE 'D', 'E', AND 'F' SIGNS ON 'U' CHANNEL POSTS

GENERAL NOTES

- .SIGNS FURNISHED BY CONTRACTOR
- .ALL TYPE 'E' SIGNS SHALL BE MOUNTED ON ONE U-CHANNEL POST UNLESS OTHERWISE INDICATED ON THE PLANS.
- .WHEN NOT STATIONED OR DIMENSIONED ON PLANS, ALL 'E' AND 'F' SIGNS SHALL BE FIELD LOCATED BY THE ENGINEER.
- .IF REMOVAL OR RELOCATIO OF SIGNS ON PRIVATE STREET (NON-STATE MAINTAINED) IS REQUIRED DUE TO CONSTRUCTION, THE CONTRACTOR SHALL INFORM THE ENGINEER. THE WORK WILL BE COMPLETED BY OTHERS.
- .WHEN EXISTING SIGNS ARE REMOVED AND INSTALLED ON NEW SUPPORTS, THE RE-ERECTION SHALL IMMEDIATELY FOLLOW THE REMOVAL.
- .SEE ROADWAY PLANS FOR GUARD/GUIDE RAIL DETAILS.
- .THE BACKGROUND FOR TYPE E SIGNS SHALL BE TYPE C REFLECTIVE SHEETING.

SUMMARY OF QUANTITIES

ITEM NO.		ITEM DESCRIPTION	QUANTITY	UNIT
DESC. NO.	SECT. NO.			
4025000000-E	901	CONTRACTOR FURNISHED, TYPE E SIGN	67	SF
4072000000-E	903	SUPPORTS, 3LB U-CHANNEL	170	LF
4102000000-N	904	SIGN ERECTION, TYPE E	23	EA
4116100000-N	904	SIGN ERECTION, RELOCATE TYPE E	3	EA
4155000000-N	907	DISPOSAL OF SIGN SYSTEM, U-CHANNEL	4	EA
4192000000-N	907	DISPOSAL OF SUPPORT, U-CHANNEL	3	EA

INDEX

SHEET NO.	DESCRIPTION
SIGN-1	TITLE SHEET
SIGN-3-4	EXISTING SIGN PLAN SHEETS
SIGN-5-6	PROPOSED SIGN PLAN SHEETS

TIP NO. R-5967	SHEET NO. SHEET 2
DocuSigned by: <i>William C Carver</i>	
APPROVED: _____	
DATE: 08/15/2023	
SEAL	
DOCUMENT NOT CONSIDERED FINAL UNLESS ALL SIGNATURES COMPLETED	

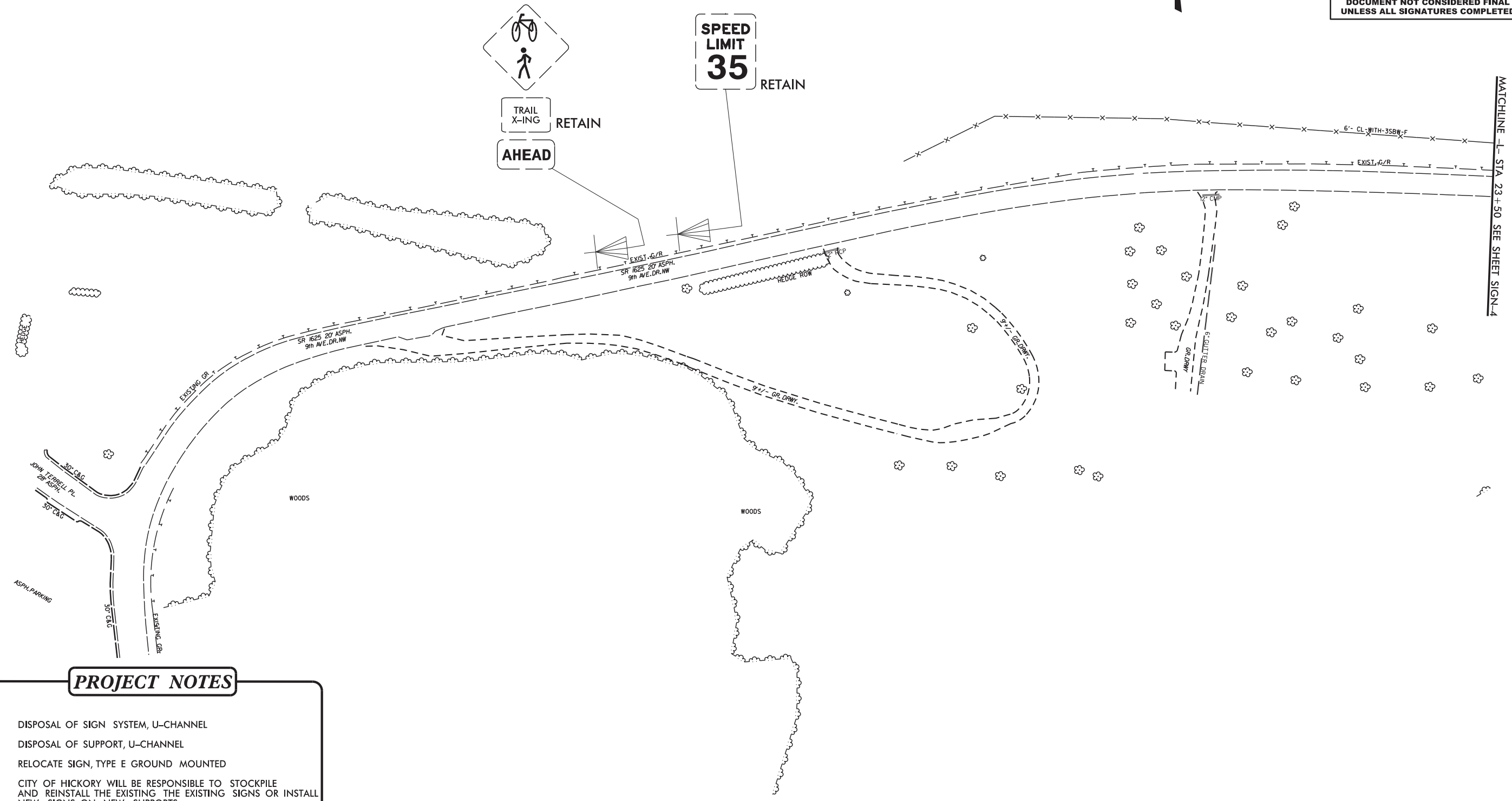

MATCHLINE - STA 23+50 SEE SHEET SIGN-4

PROJECT NOTES

- 1 DISPOSAL OF SIGN SYSTEM, U-CHANNEL
- 2 DISPOSAL OF SUPPORT, U-CHANNEL
- 3 RELOCATE SIGN, TYPE E GROUND MOUNTED
- * CITY OF HICKORY WILL BE RESPONSIBLE TO STOCKPILE AND REINSTALL THE EXISTING THE EXISTING SIGNS OR INSTALL NEW SIGNS ON NEW SUPPORTS.

EXISTING SIGNS
SR 1622 (9TH AVE. DRIVE NW)
10+00± TO 23+50±

25 JUL 2023 09:26
C:\Users\carver\OneDrive\Documents\Projects\SR1622\Signing\SR1622_SGN_3.dgn

TIP NO. R-5967	SHEET NO. 15
DocuSigned by: <i>William C Carver</i>	
APPROVED: _____	
DATE: 08/15/2023	
SEAL	
DOCUMENT NOT CONSIDERED FINAL UNLESS ALL SIGNATURES COMPLETED	



15

20

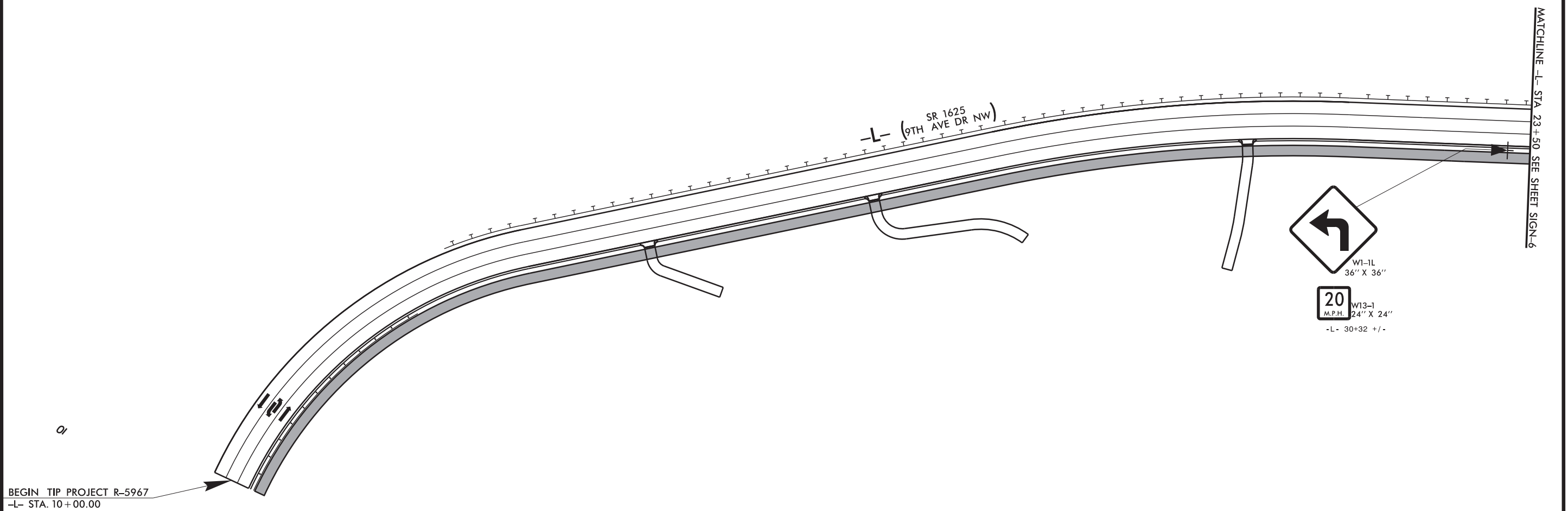

BEGIN TIP PROJECT R-5967
-L- STA. 10+00.00

MATCHLINE -L- STA. 23+50 SEE SHEET SIGN-6

PROJECT NOTES

- 1 DISPOSAL OF SIGN SYSTEM, U-CHANNEL
- 2 DISPOSAL OF SUPPORT, U-CHANNEL
- 3 RELOCATE SIGN, TYPE E GROUND MOUNTED
- * CITY OF HICKORY WILL BE RESPONSIBLE TO STOCKPILE AND REINSTALL THE EXISTING THE EXISTING SIGNS OR INSTALL NEW SIGNS ON NEW SUPPORTS.

PROPOSED SIGNS
SR 1622 (9TH AVE. DRIVE NW)
10+00± TO 23+50±

25 JUL 2023 09:33
C:\Users\jcarver\OneDrive\Work\Projects\SR1622\Signing\SR1622_Sign\5.dgn

PROJECT NOTES

- 1 DISPOSAL OF SIGN SYSTEM, U-CHANNEL
- 2 DISPOSAL OF SUPPORT, U-CHANNEL
- 3 RELOCATE SIGN, TYPE E GROUND MOUNTED
- * CITY OF HICKORY WILL BE RESPONSIBLE TO STOCKPILE AND REINSTALL THE EXISTING THE EXISTING SIGNS OR INSTALL NEW SIGNS ON NEW SUPPORTS.

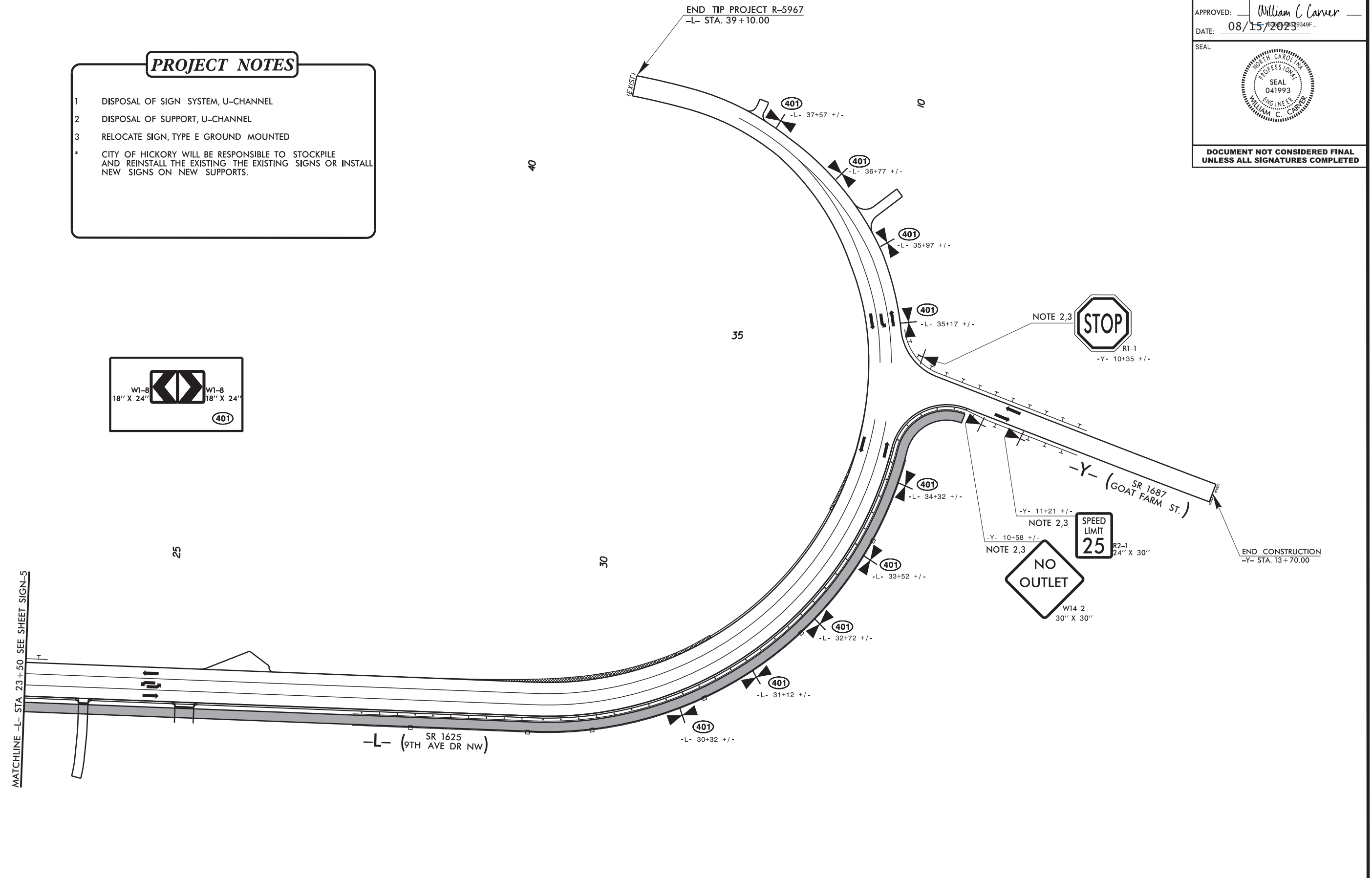

25 JUL 2023 09:35
C:\Users\carver\OneDrive\Desktop\Traffic\Signing\R5967\ddc_SGN_6.dgn

PROPOSED SIGNS
 SR 1622 (9TH AVE. DRIVE NW) 23+50± TO 39+10±
 SR 1687 (GOAT FARM ROAD) 10+00± TO 13+70±

09/08/99

TIP PROJECT: R-5967

T.I.P. NO.	SHEET NO.
R-5967	UC-1

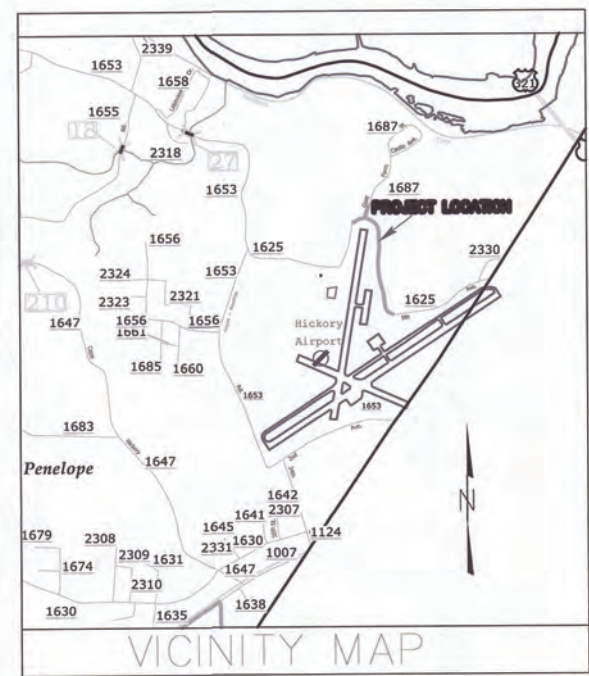

STATE OF NORTH CAROLINA
 DIVISION OF HIGHWAYS
 UTILITY CONSTRUCTION PLANS
 CITY OF HICKORY

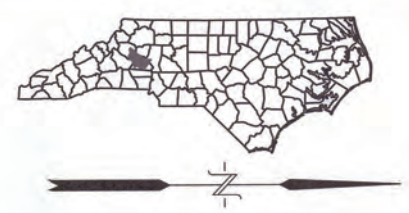

LOCATION: 9TH AVE DR NE (SR2330) FROM HICKORY
 REGIONAL AIRPORT ENTRANCE TO
 GOAT FARM RD (SR1687)

TYPE OF WORK: WATER LINE RELOCATION

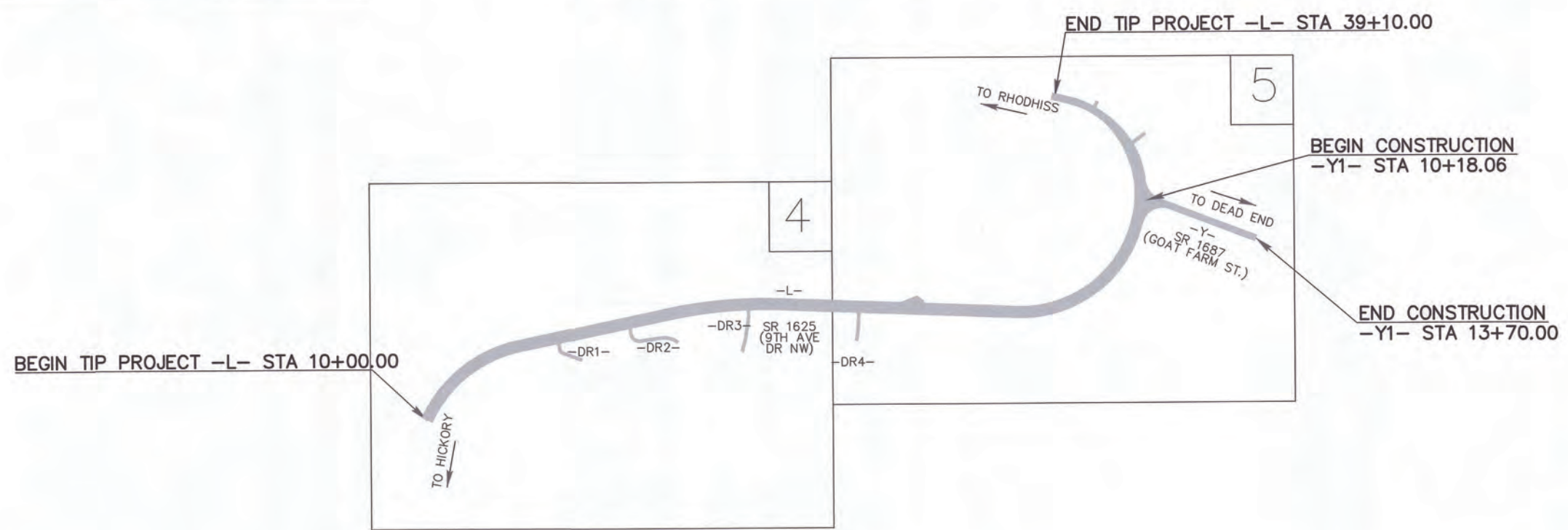

DOCUMENT NOT CONSIDERED FINAL
 UNTIL ALL SIGNATURES ARE COMPLETED

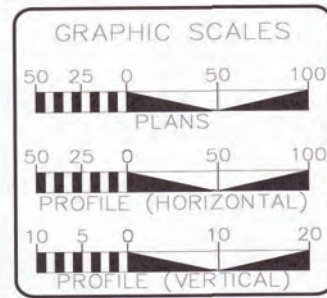

SHEET NO.:	DESCRIPTION:
UC-1	TITLE SHEET
UC-2	UTILITY SYMBOLOGY
UC-3	NOTES
UC-4 THRU UC-5	DETAILS
UC-6 THRU UC-7	UTILITY CONSTRUCTION SHEETS
UC-8 THRU UC-10	PROFILE SHEETS

WATER AND SEWER OWNERS ON PROJECT

(A) WATER - CITY OF HICKORY
 (B) SANITARY SEWER - CITY OF HICKORY

PLANS PREPARED BY:

HICKORY CITY OF HICKORY
 1441 8TH AVE NE
 HICKORY, NC 28501
 PH (828) 323-7427

CALEB BYNUM, PE UTILITIES ENGINEER
 WILL HAMBUN, PE PROJECT MANAGER
 JOHN MARSHALL, TRANSPORTATION MANAGER



DIVISION OF HIGHWAYS
 UTILITIES UNIT
 1800 MAIL SERVICES CENTER
 RALEIGH, NC 27699-1885
 PHONE (919) 707-6880
 FAX (919) 250-4181

XXXX UTILITIES REGIONAL ENGINEER
 XXXX UTILITIES ENGINEER
 XXXX UTILITIES AREA COORDINATOR
 XXXX UTILITIES COORDINATOR

UTILITY CONSTRUCTION NOTES

PROJECT REFERENCE NO. R-5967	SHEET NO. UC-3
DESIGNED BY: CMB	
DRAWN BY: -	
CHECKED BY: -	
APPROVED BY: -	
REVISED: -	
NORTH CAROLINA DEPARTMENT OF TRANSPORTATION UTILITIES ENGINEERING SEC. PHONE: (919)707-6690 FAX: (919)250-4151	

UTILITY CONSTRUCTION

**DOCUMENT NOT CONSIDERED FINAL
UNLESS ALL SIGNATURES COMPLETED**

GENERAL NOTES:

1. THE PROPOSED UTILITY CONSTRUCTION SHALL MEET THE REQUIREMENTS OF APPLICABLE SECTIONS OF THE CITY OF HICKORY'S MANUAL OF PRACTICE AS SUBMITTED TO NCDEQ DURING PERMITTING.
2. THE EXISTING WATER UTILITIES BELONG TO THE CITY OF HICKORY.
3. ALL WATER LINES ARE TO BE INSTALLED WITHIN COMPLIANCE OF THE RULES AND REGULATION OF THE NORTH CAROLINA DEPARTMENT OF ENVIRONMENTAL QUALITY, DIVISION OF WATER RESOURCES, PUBLIC WATER SUPPLY SECTION. PERFORM ALL WORK IN ACCORDANCE WITH THE APPLICABLE PLUMBING CODES.
4. THE UTILITY OWNER OWNS THE EXISTING UTILITY FACILITIES AND WILL OWN THE NEW UTILITY FACILITIES AFTER ACCEPTANCE BY THE DEPARTMENT. THE DEPARTMENT OWNS THE CONSTRUCTION CONTRACT AND HAS ADMINISTRATIVE AUTHORITY. COMMUNICATIONS AND DECISIONS BETWEEN THE CONTRACTOR AND THE UTILITY OWNER ARE NOT BINDING UPON THE DEPARTMENT OR THIS CONTRACT UNLESS AUTHORIZED BY THE ENGINEER. AGREEMENTS BETWEEN THE UTILITY OWNER AND CONTRACTOR FOR ANY WORK THAT IS NOT PART OF THIS CONTRACT OR IS SECONDARY TO THIS CONTRACT ARE ALLOWED, BUT ARE NOT BINDING UPON THE DEPARTMENT.
5. PROVIDE ACCESS FOR THE DEPARTMENT PERSONNEL AND THE OWNER'S REPRESENTATIVES TO ALL PHASES OF CONSTRUCTION. NOTIFY DEPARTMENT PERSONNEL AND THE UTILITY OWNER TWO WEEKS PRIOR TO THE COMMENCEMENT OF ANY WORK AND ONE WEEK PRIOR TO SERVICE INTERRUPTION. KEEP OWNERS' REPRESENTATIVES INFORMED OF WORK PROGRESS AND PROVIDE OPPORTUNITY FOR INSPECTION OF CONSTRUCTION AND TESTING.

6. THE PLANS DEPICT THE BEST AVAILABLE INFORMATION FOR THE LOCATION, SIZE, AND TYPE OF MATERIAL FOR ALL EXISTING UTILITIES. MAKE INVESTIGATIONS FOR DETERMINING THE EXACT LOCATION, SIZE, AND TYPE MATERIAL OF THE EXISTING FACILITIES AS NECESSARY FOR THE CONSTRUCTION OF THE THE PROPOSED UTILITIES AND FOR AVOIDING DAMAGE TO EXISTING FACILITIES. REPAIR ANY DAMAGE INCURRED TO EXISTING FACILITIES TO THE ORIGINAL OR BETTER CONDITION AT NO ADDITIONAL COST TO THE DEPARTMENT.
7. MAKE FINAL CONNECTIONS OF THE NEW WORK TO THE EXISTING SYSTEM WHERE INDICATED ON THE PLANS, AS REQUIRED TO FIT THE ACTUAL CONDITIONS, OR AS DIRECTED.
8. MAKE CONNECTIONS BETWEEN EXISTING AND PROPOSED UTILITIES AT TIMES MOST CONVENIENT TO THE PUBLIC, WITHOUT ENDANGERING THE UTILITY SERVICE, AND IN ACCORDANCE WITH THE UTILITY OWNER'S REQUIREMENTS. MAKE CONNECTIONS ON WEEKENDS, AT NIGHT, AND ON HOLIDAYS IF NECESSARY.
9. ALL UTILITY MATERIALS SHALL BE APPROVED PRIOR TO DELIVERY TO THE PROJECT.

PROJECT SPECIFIC NOTES:

1. ALL PROPOSED DUCTILE IRON WATER LINE 6 - 16 INCHES IN DIAMETER, SHALL BE PRESSURE CLASS 350 AND UTILIZE FLEXIBLE PUSH-ON JOINTS.
2. ALL WATER LINE FITTINGS 4-12 INCHES IN DIAMETER, SHALL BE PRESSURE CLASS 350 DUCTILE IRON RESTRAINED JOINT IN ACCORDANCE WITH ANSI A21.10 / AWWA C110 AND ANSI A21.4 / AWWA C104.
3. WATER LINE UTILIZING RESTRAINED JOINTS SHALL BE TYTON JOINT, HP LOK, AMERICAN "FAST GRIP", US PIPE "FIELD-LOK" OR APPROVED EQUAL.
4. ALL WATERLINE SHALL HAVE COAT3ED TRACER WIRE NO SMALLER THAN 14 AWG SOLID COPPER.
5. ALL VALVES - 2" THROUGH 16" SHALL BE RESILIENT WEDGE GATE, CAST IRON BODY, CONFORMING TO AWWA C509, LATEST VERSION. SEALING MECHANISM SHALL PROVIDE ZERO LEAKAGE AT THE WATER WORKING PRESSURE AGAINST THE LINE FLOW FROM EITHER DIRECTION AND BE DESIGNED SUCH THAT NO EXPOSED METAL SEAMS, EDGES, SCREWS, ETC. ARE WITHIN THE WATERWAY IN THE CLOSED POSITION. THE GATE SHALL NOT BE WEDGED INTO A POCKET NOR SLIDE ACROSS THE SEATING SURFACE TO OBTAIN TIGHT CLOSURE. ALL INTERNAL AND EXTERNRNAL FERROUS SURFACES OF THE VALVE , INCLUDING THE INTERIOR OF THE GATE, SHALL BE COATED WITH A PROTECTIVE COATING CONFORMING TO AWWA C550, LATEST VERSION. COATING SHALL BE APPLIED TO CASTINGS PRIOR TO ASSEMBLY TO ASSURE ALL EXPOSED AREAS WILL BE COVERED. VALVES SHALL BE RATED AT 200 PSI WORKING PRESSURE. UNLESS OTHERWISE NOTED, UNDERGROUND VALVES SHALL HAVE AN OPERATING NUT AND EXPOSED VALVES SHALL HAVE A HAND WHEEL OPERATOR. OPERATING NUT SHALL BE 2"X2:, OPEN LEFT.
6. EACH VALVE BURIED IN THE GROUND SHALL BE PROVIDED WITH AN APPROVED TYPE OF VALVE BOX AND COVER. THE BOXES SHALL BE ADJUSTABLE SCREW TYPE 24-INCH OR 36-INCH.

7. ALL VALVE BOXES SHALL BE CONSTRUCTED OF DOMESTIC OR FOREIGN CAST IRON THAT COMPLIES WITH THE REQUIREMENTS OF ASTM A48. VALVE BOXES SHALL BE THE APPROPRIATE RANGE OF ADJUSTMENT FOR THE SITE AND CONTRACTOR SHOULD MINIMIZE THE USE OF EXTENSIONS.
8. PROVIDE THRUST RESTRAINT ON THE EXISTING WATER LINE WHERE TIE-INS ARE MADE AS NECESSARY.
9. CONTRACTOR SHALL NOT OPERATE ANY VALVES ON THE EXISTING UTILITY SYSTEMS. CONTRACTOR SHALL CONTACT THE UTILITY OWNER TO CONDUCT STRATEGIC OPERATION OF VALVES FOR SERVICE INTERRUPTION IN ORDER TO PERFORM SPECIFIC WORK.
10. ANY BENDS OF WATER PIPE NOT SPECIFICALLY CALLED OUT WITH A 90, 45, 22.5, OR 11.25 DEGREE BEND FITTING, SHALL BE CONSTRUCTED BY A RADIAL BEND OF THE PIPE AS NOTED ON THE PLANS OR IN ACCORDANCE WITH THE PIPE MANUFACTURERS SPECIFICATIONS (WHICHEVER IS MORE STRINGENT) - OR A COMBINATION OF BEND FITTINGS AND RADIAL BEND OF THE PIPE.
11. ALL MATERIALS, EQUIPMENT, LABOR, AND WORKMANSHIP SHALL BE IN ACCORDANCE WITH CITY OF HICKORY STANDARDS AND NCDOT STANDARD SPECIFICATIONS FOR ROADS AND STRUCTURES FOR PROPOSED WATER LINES. IN THE EVENT OF A CONFLICT BETWEEN STANDARDS, THE MORE RESTRICTIVE REQUIREMENTS SHALL APPLY.
12. UTILITY OWNER MUST BE PRESENT FOR ANY TESTING OR CONNECTIONS TO THE EXISTING SYSTEM INCLUDING BUT NOT LIMITED TO ALL TAPS AND TEMPORARY CONSTRUCTION CONNECTIONS. A NOTICE OF 72 HOURS MUST BE PROVIDED.

PROJECT TYPICAL DETAILS

UTILITY CONSTRUCTION
 DOCUMENT NOT CONSIDERED FINAL
 UNLESS ALL SIGNATURES COMPLETED

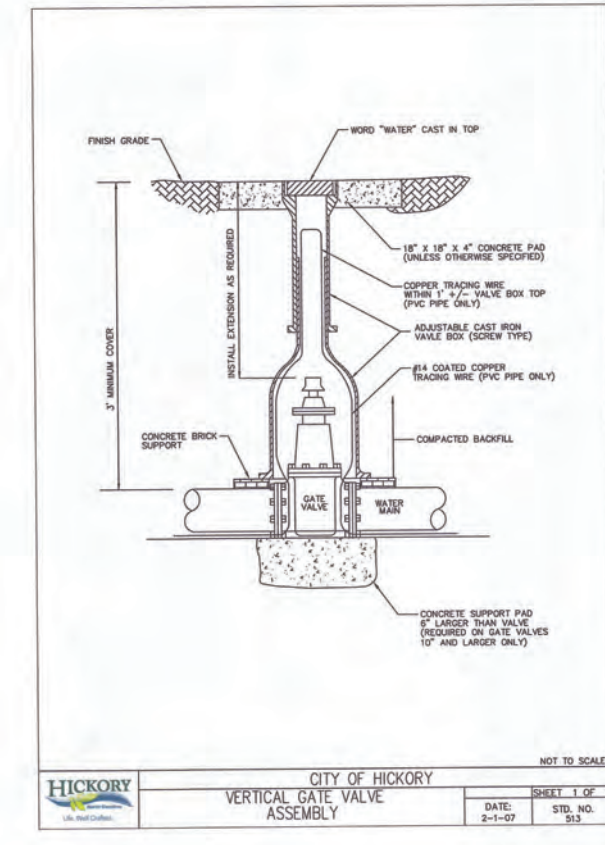
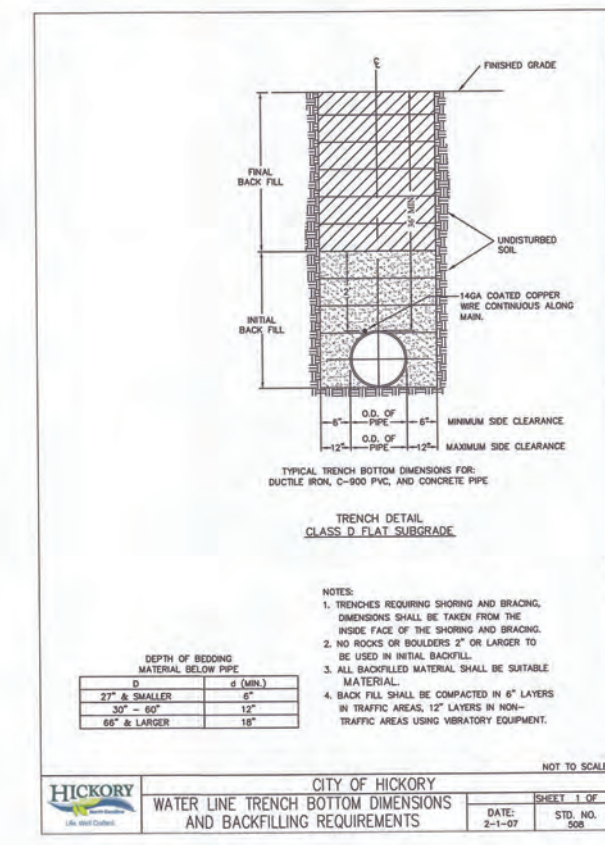
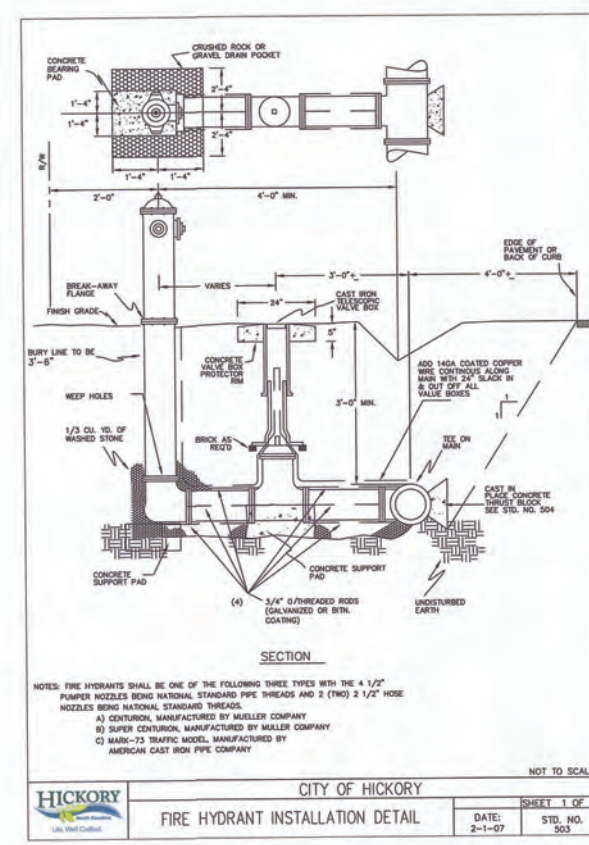
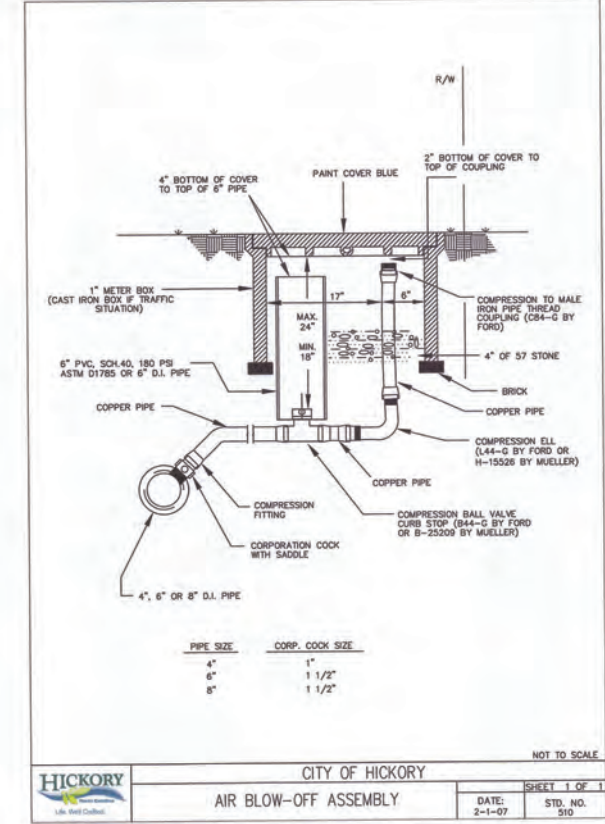
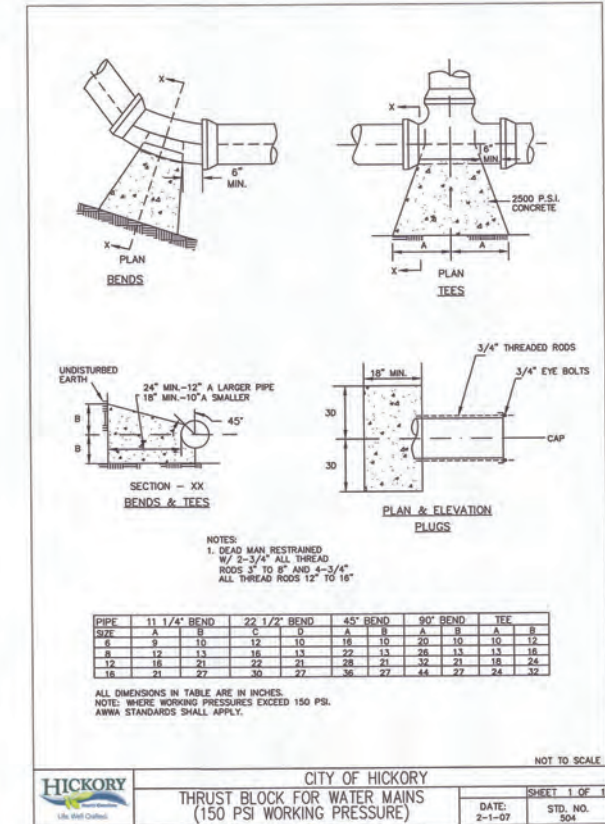
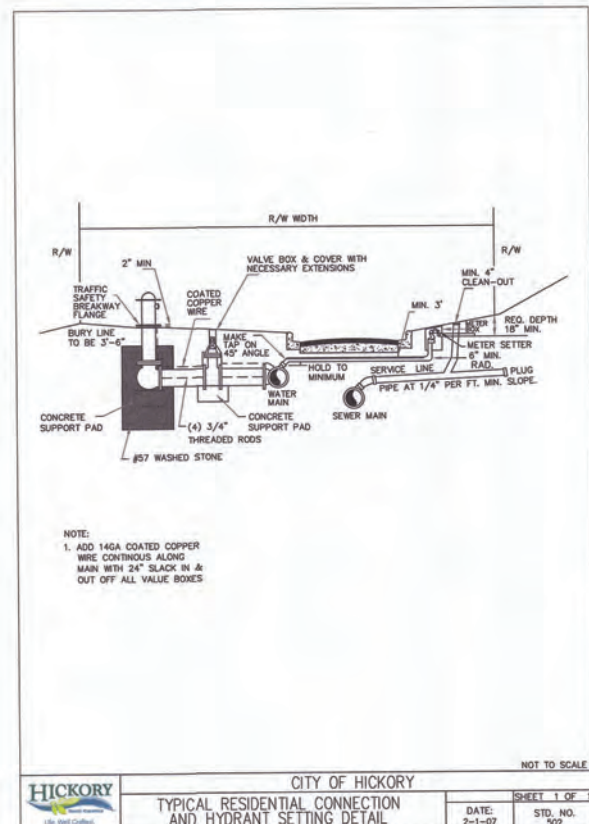

5/14/98

PROJECT TYPICAL DETAILS

PROJECT REFERENCE NO.	SHEET NO.
R-5967	UC-5
DESIGNED BY: CMB	
DRAWN BY: —	
CHECKED BY: —	
APPROVED BY: —	
REVISED: —	
NORTH CAROLINA DEPARTMENT OF TRANSPORTATION UTILITIES ENGINEERING SEC. PHONE: (919)707-6690 FAX: (919)250-4151	
UTILITY CONSTRUCTION PLANS ONLY	

UTILITY CONSTRUCTION
 DOCUMENT NOT CONSIDERED FINAL
 UNLESS ALL SIGNATURES COMPLETED

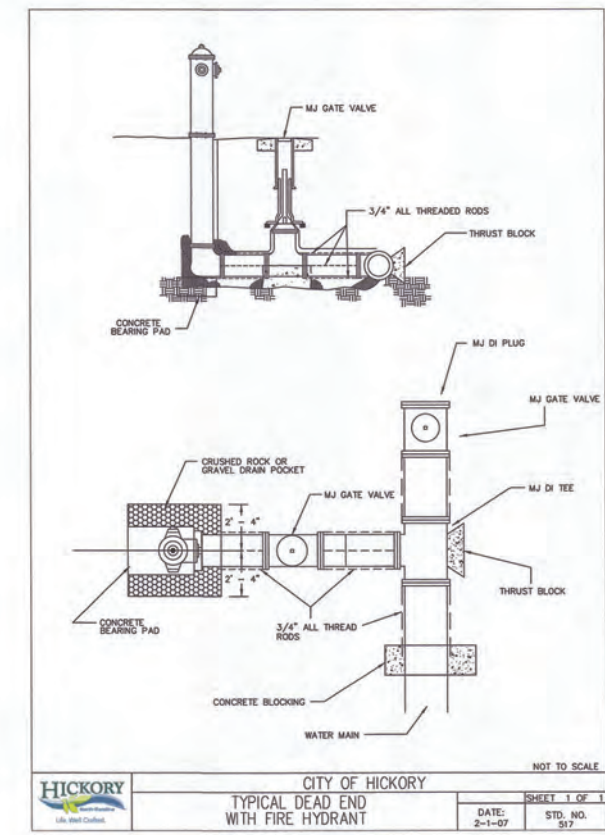
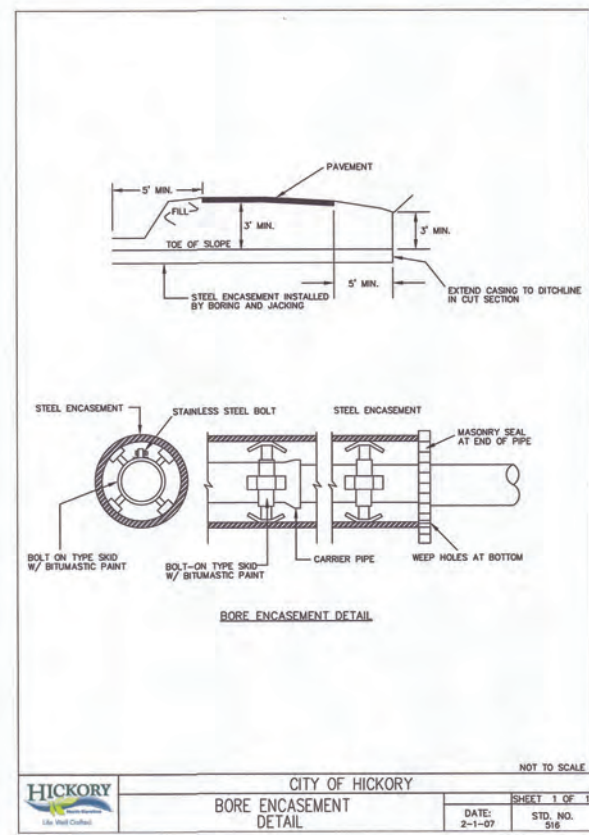
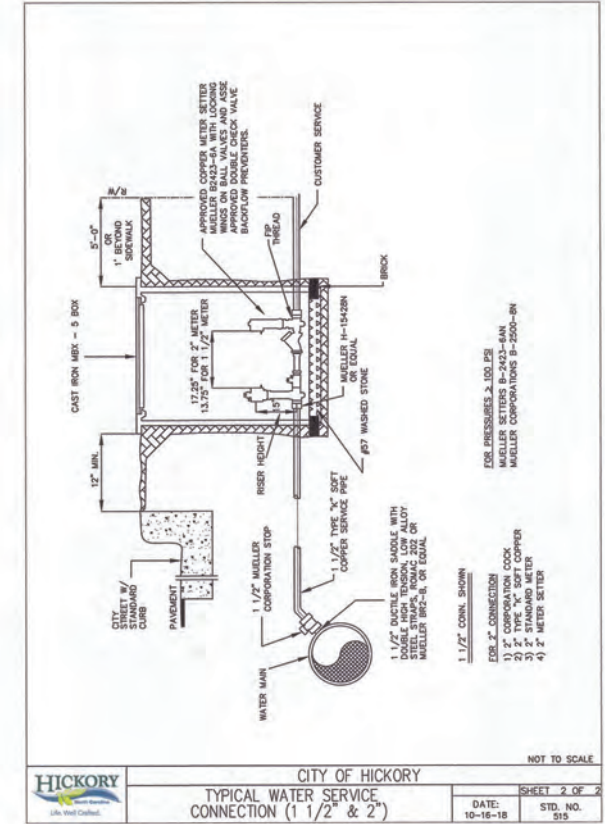
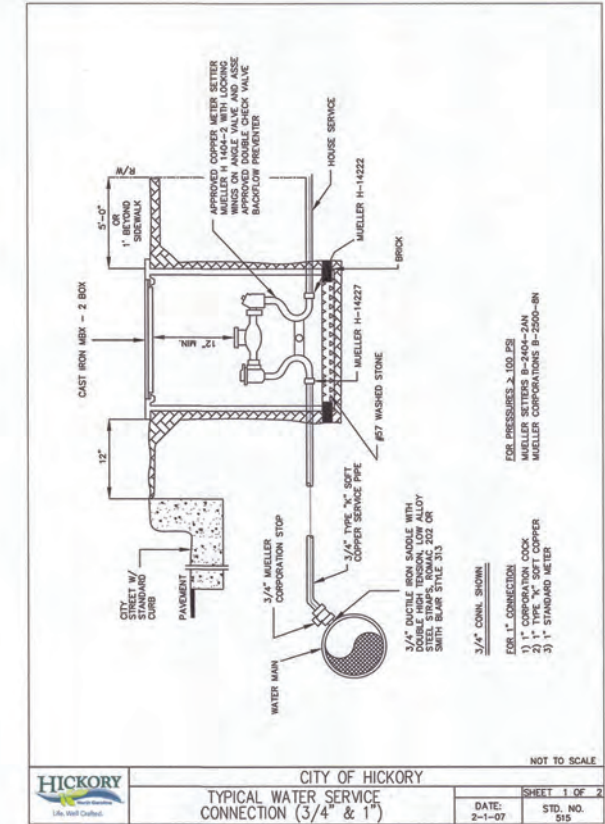
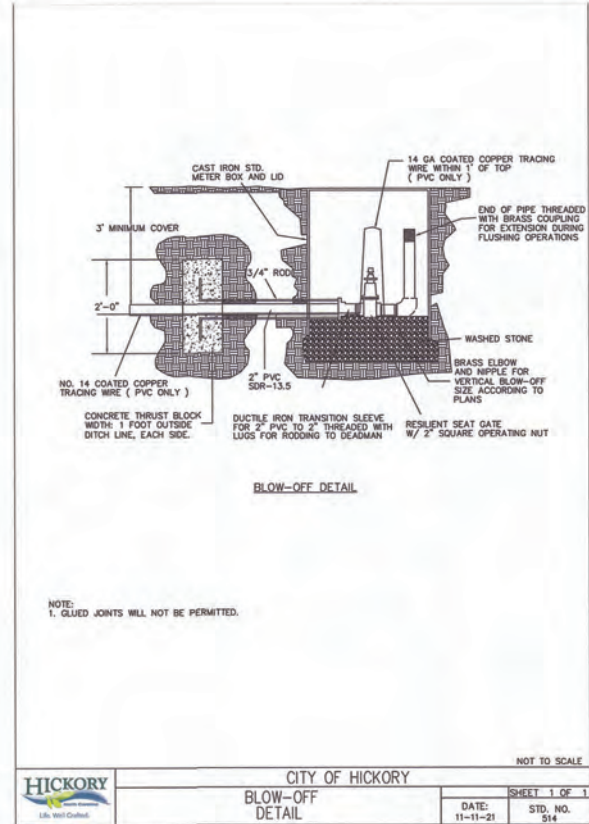

PROJECT REFERENCE NO.	SHEET NO.
R-5967	UC-7
DESIGNED BY: CMB	
DRAWN BY: -	
CHECKED BY: -	
APPROVED BY: -	
REVISED: -	
NORTH CAROLINA DEPARTMENT OF TRANSPORTATION UTILITIES ENGINEERING SEC. PHONE: (919)707-6690 FAX: (919)250-4151	
UTILITY CONSTRUCTION PLANS ONLY	

SEE SHEET UC-8 & UC-9 FOR 16" WL-1 PROFILE
 SEE SHEET UC-10 FOR 8" WL-2 PROFILE

R = 380.00'	OS = 45	SP = 0.06
R = 291.64'	OS = 45	SP = 0.06
R = 438.81'	OS = 45	SP = 0.06
R = 10,081.58'	OS = 45	SP = 0.06

Sta	10+53.41	11+16.97
PI	10+53.41	11+16.97
Δ	28° 38' 52.4"	30° 54' 10.6"
Δ/2	14° 19' 26.2"	15° 27' 05.3"
Δ/2	12° 15'	12° 15'
Δ/2	6.08'	6.08'
Δ/2	200.00'	200.00'

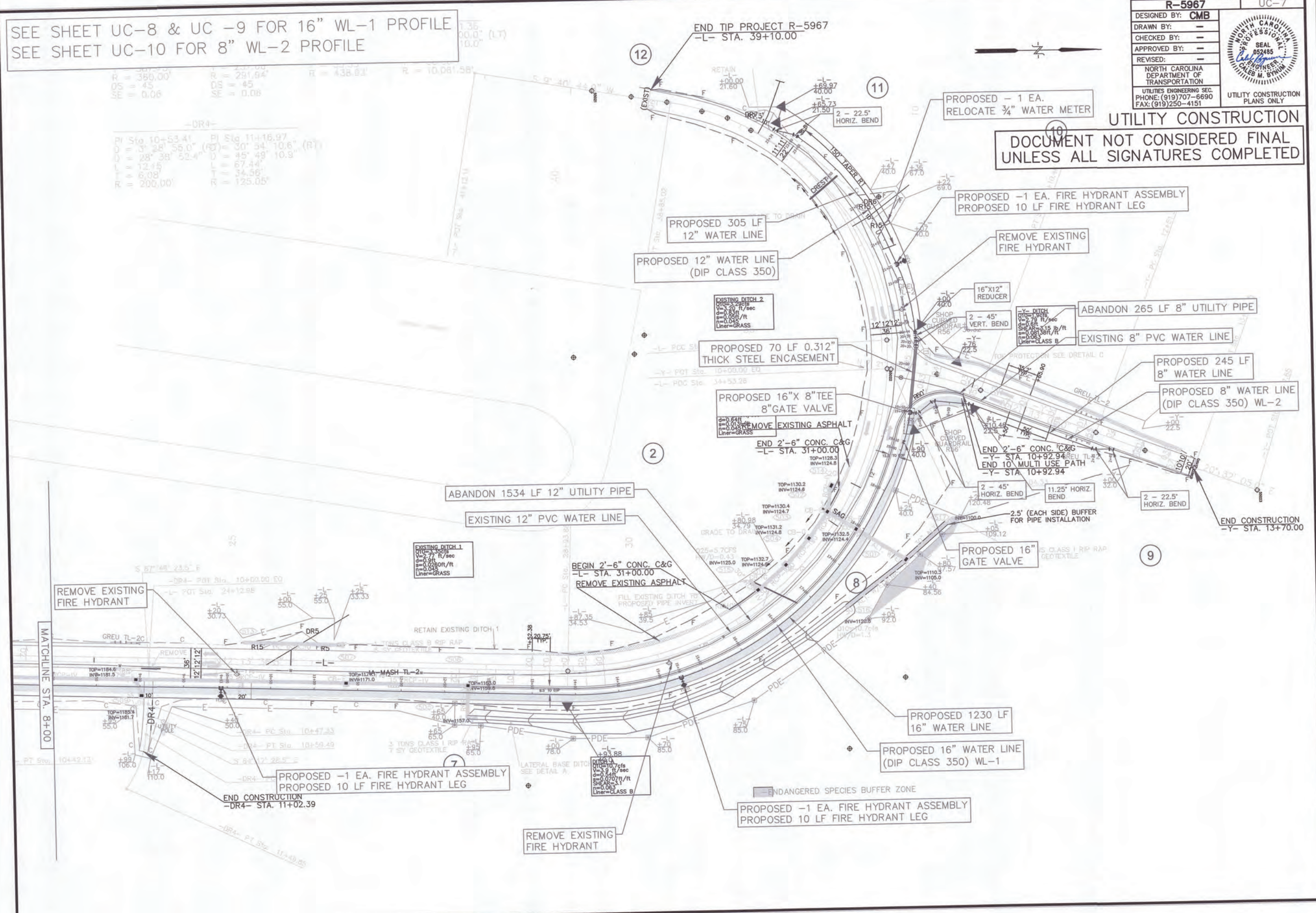

UTILITY CONSTRUCTION
 DOCUMENT NOT CONSIDERED FINAL
 UNLESS ALL SIGNATURES COMPLETED

MATCHLINE STA. 8+00

REMOVE EXISTING
FIRE HYDRANT

PROPOSED -1 EA. FIRE HYDRANT ASSEMBLY
 PROPOSED 10 LF FIRE HYDRANT LEG

REMOVE EXISTING
FIRE HYDRANT

PROPOSED -1 EA. FIRE HYDRANT ASSEMBLY
 PROPOSED 10 LF FIRE HYDRANT LEG

PROPOSED 1230 LF
16" WATER LINE

PROPOSED 16" WATER LINE
(DIP CLASS 350) WL-1

PROPOSED 16"
GATE VALVE

PROPOSED 16" X 8" TEE
8" GATE VALVE

PROPOSED 70 LF 0.312"
THICK STEEL ENCASEMENT

PROPOSED 12" WATER LINE
(DIP CLASS 350)

PROPOSED 305 LF
12" WATER LINE

PROPOSED -1 EA. FIRE HYDRANT ASSEMBLY
 PROPOSED 10 LF FIRE HYDRANT LEG

REMOVE EXISTING
FIRE HYDRANT

ABANDON 265 LF 8" UTILITY PIPE

EXISTING 8" PVC WATER LINE

PROPOSED 245 LF
8" WATER LINE

PROPOSED 8" WATER LINE
(DIP CLASS 350) WL-2

END CONSTRUCTION
-Y- STA. 13+70.00

END CONSTRUCTION
-DR4- STA. 11+02.39

END 2'-6" CONC. C&G
-L- STA. 31+00.00

END 2'-6" CONC. C&G
-Y- STA. 10+92.94

END 10' MULTI USE PATH
-Y- STA. 10+92.94

END 2'-6" CONC. C&G
-L- STA. 31+00.00

END 2'-6" CONC. C&G
-Y- STA. 10+92.94

END 10' MULTI USE PATH
-Y- STA. 10+92.94

ABANDON 1534 LF 12" UTILITY PIPE

EXISTING 12" PVC WATER LINE

BEGIN 2'-6" CONC. C&G
-L- STA. 31+00.00

REMOVE EXISTING ASPHALT

2 - 45' HORIZ. BEND

11.25' HORIZ. BEND

2 - 22.5' HORIZ. BEND

2.5' (EACH SIDE) BUFFER
FOR PIPE INSTALLATION

REMOVE EXISTING
FIRE HYDRANT

EXISTING DITCH 1
V=2.77 ft/sec
d=12"
s=0.020 ft/ft
Liner=GRASS

END 2'-6" CONC. C&G
-L- STA. 31+00.00

END 2'-6" CONC. C&G
-Y- STA. 10+92.94

END 10' MULTI USE PATH
-Y- STA. 10+92.94

RETAIN EXISTING DITCH 1

REMOVE EXISTING ASPHALT

ENDANGERED SPECIES BUFFER ZONE

5/14/99

5/14/99

16" WATER LINE WL-1

PROJECT REFERENCE NO. R-5967	SHEET NO. UC-8
DESIGNED BY: CMB	
DRAWN BY: -	
CHECKED BY: -	
APPROVED BY: -	
REVISD: -	
NORTH CAROLINA DEPARTMENT OF TRANSPORTATION UTILITIES ENGINEERING SEC. PHONE: (919) 707-6890 FAX: (919) 250-4151	
UTILITY CONSTRUCTION PLANS ONLY	

UTILITY CONSTRUCTION

DOCUMENT NOT CONSIDERED FINAL
UNLESS ALL SIGNATURES COMPLETED

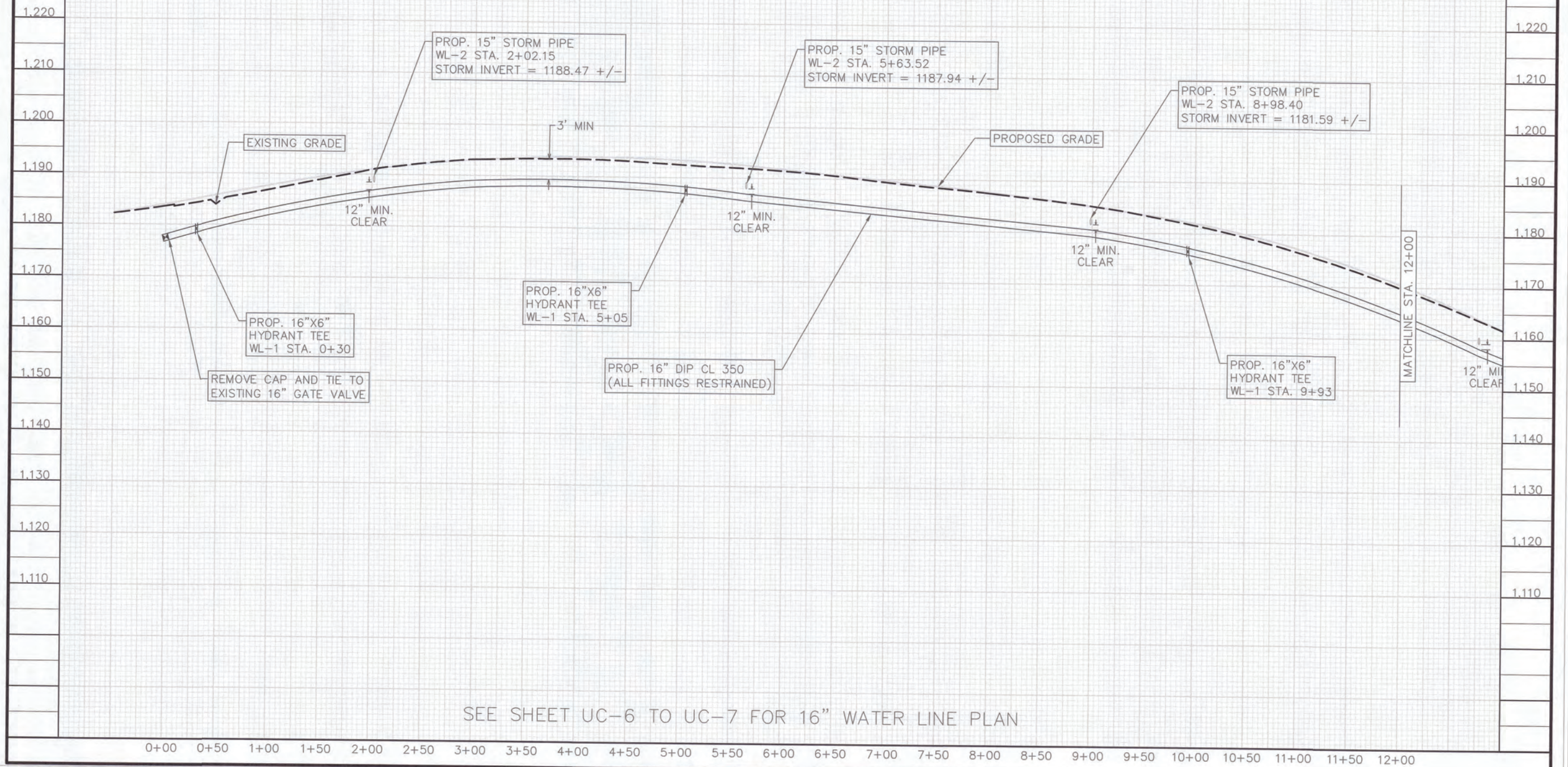

SEE SHEET UC-6 TO UC-7 FOR 16" WATER LINE PLAN

16" WATER LINE WL-1

PROJECT REFERENCE NO. R-5967	SHEET NO. UC-9
DESIGNED BY: CMB	
DRAWN BY: —	
CHECKED BY: —	
APPROVED BY: —	
REVISED: —	
NORTH CAROLINA DEPARTMENT OF TRANSPORTATION UTILITIES ENGINEERING SEC. PHONE: (919)707-8690 FAX: (919)250-4151	
UTILITY CONSTRUCTION PLANS ONLY	

UTILITY CONSTRUCTION

DOCUMENT NOT CONSIDERED FINAL
UNLESS ALL SIGNATURES COMPLETED

5/14/99

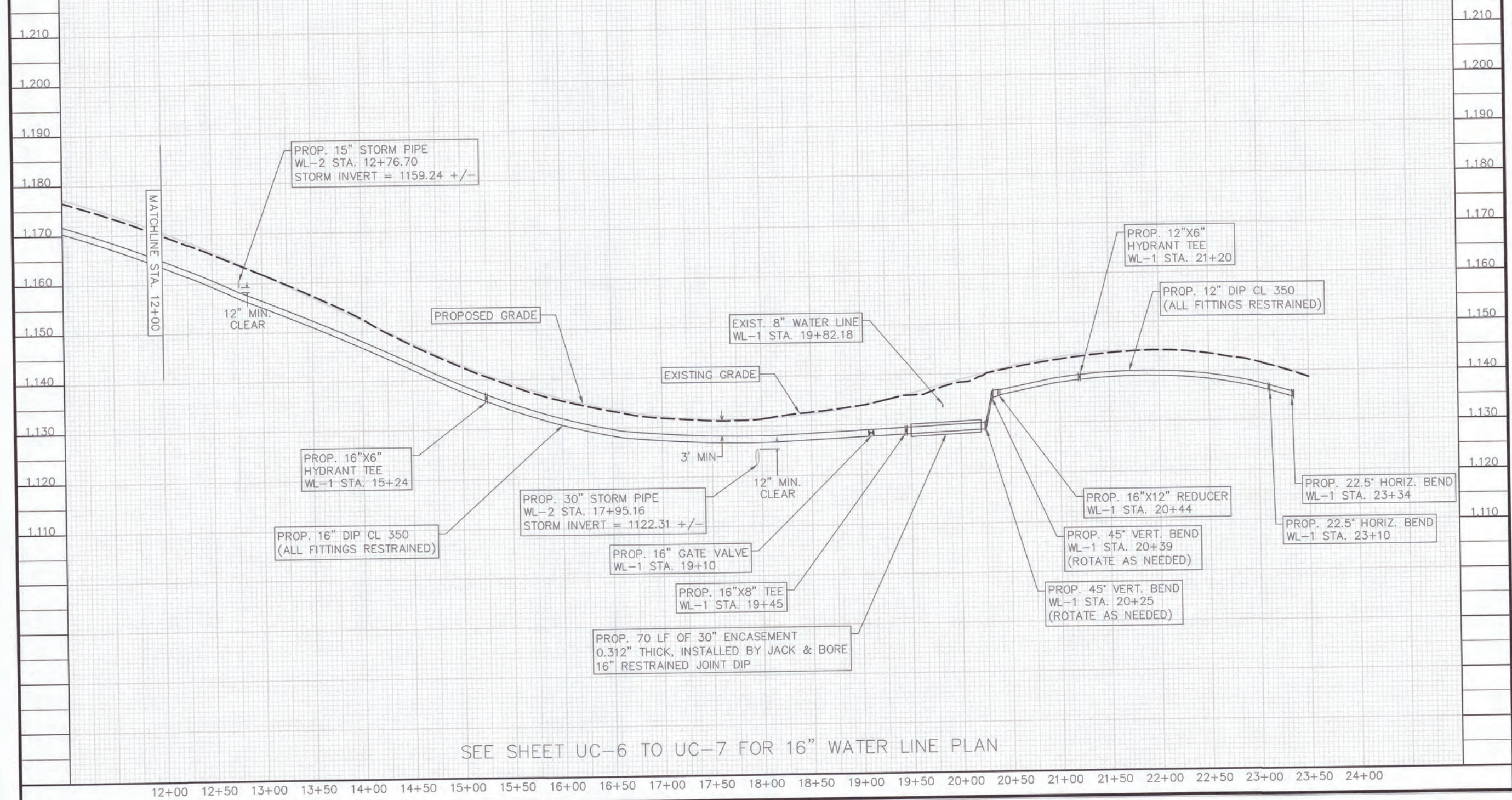

SEE SHEET UC-6 TO UC-7 FOR 16" WATER LINE PLAN

5/14/99

8" WATER LINE WL-2

PROJECT REFERENCE NO. R-5967	SHEET NO. UC-10
DESIGNED BY: CMB	
DRAWN BY: -	
CHECKED BY: -	
APPROVED BY: -	
REVISED: -	
NORTH CAROLINA DEPARTMENT OF TRANSPORTATION UTILITIES ENGINEERING SEC. PHONE: (919)707-8690 FAX: (919)250-4151	
UTILITY CONSTRUCTION PLANS ONLY	

DOCUMENT NOT CONSIDERED FINAL
UNLESS ALL SIGNATURES COMPLETED

1.200
1.190
1.180
1.170
1.160
1.150
1.140
1.130
1.120
1.110
1.100
1.090
1.080
1.070

1.190
1.180
1.170
1.160
1.150
1.140
1.130
1.120
1.110
1.100
1.090
1.080
1.070

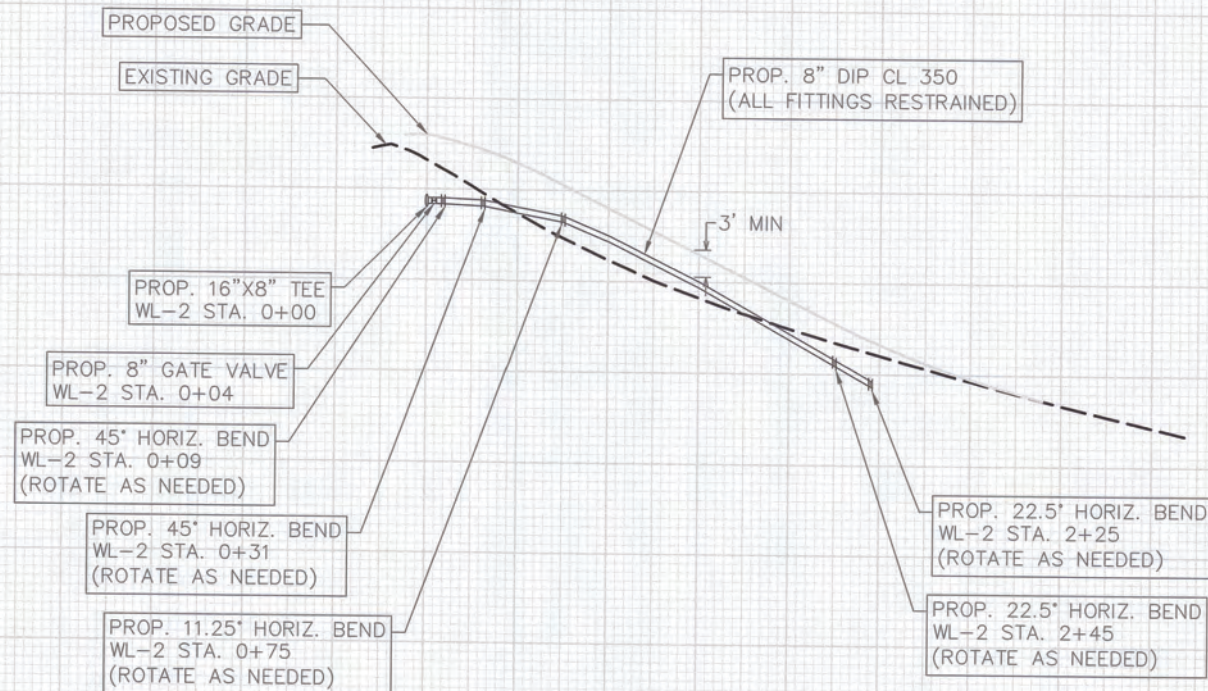

SEE SHEET UC-7 FOR 8" WATER LINE PLAN

0+00 0+50 1+00 1+50 2+00 2+50 3+00 3+50 4+00 4+50 5+00

STATE OF NORTH CAROLINA
DIVISION OF HIGHWAYS

CROSS SECTION INDEX OF SHEETS		
	CROSS-SECTION SUMMARY	X-B
-L-	10 + 00.00 TO 39 + 10.00	X-1 THRU X-11
-Y-	10 + 00.00 TO 13 + 70.00	X-12 THRU X-13
-DR1-	10 + 00.00 TO 11 + 11.11	X-14
-DR2-	10 + 00.00 TO 11 + 91.69	X-15
-DR3-	10 + 00.00 TO 11 + 44.72	X-16
-DR4-	10 + 00.00 TO 11 + 02.39	X-17

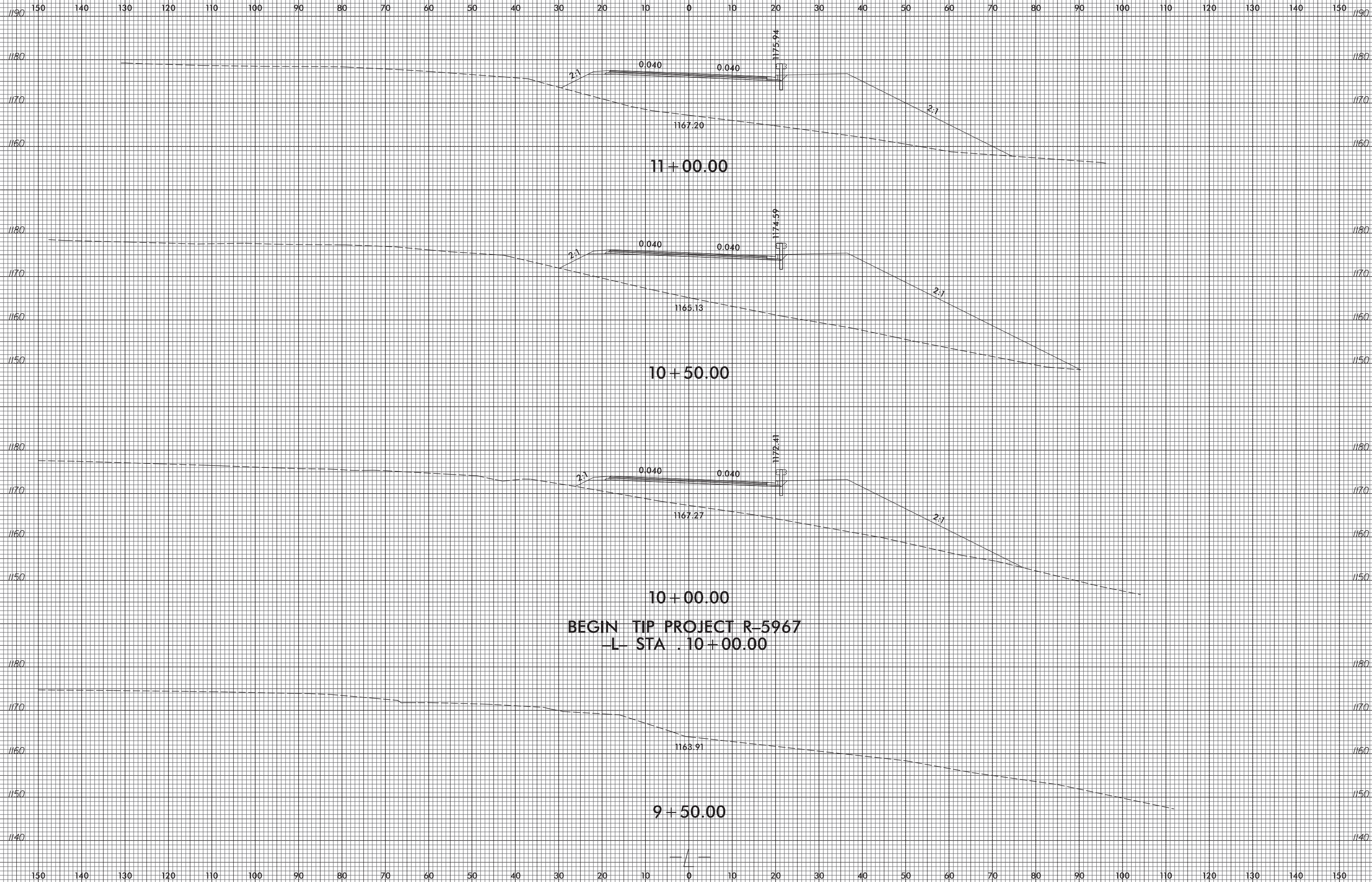

BEGIN TIP PROJECT R-5967
-L- STA . 10+00.00

150 140 130 120 110 100 90 80 70 60 50 40 30 20 10 0 10 20 30 40 50 60 70 80 90 100 110 120 130 140 150

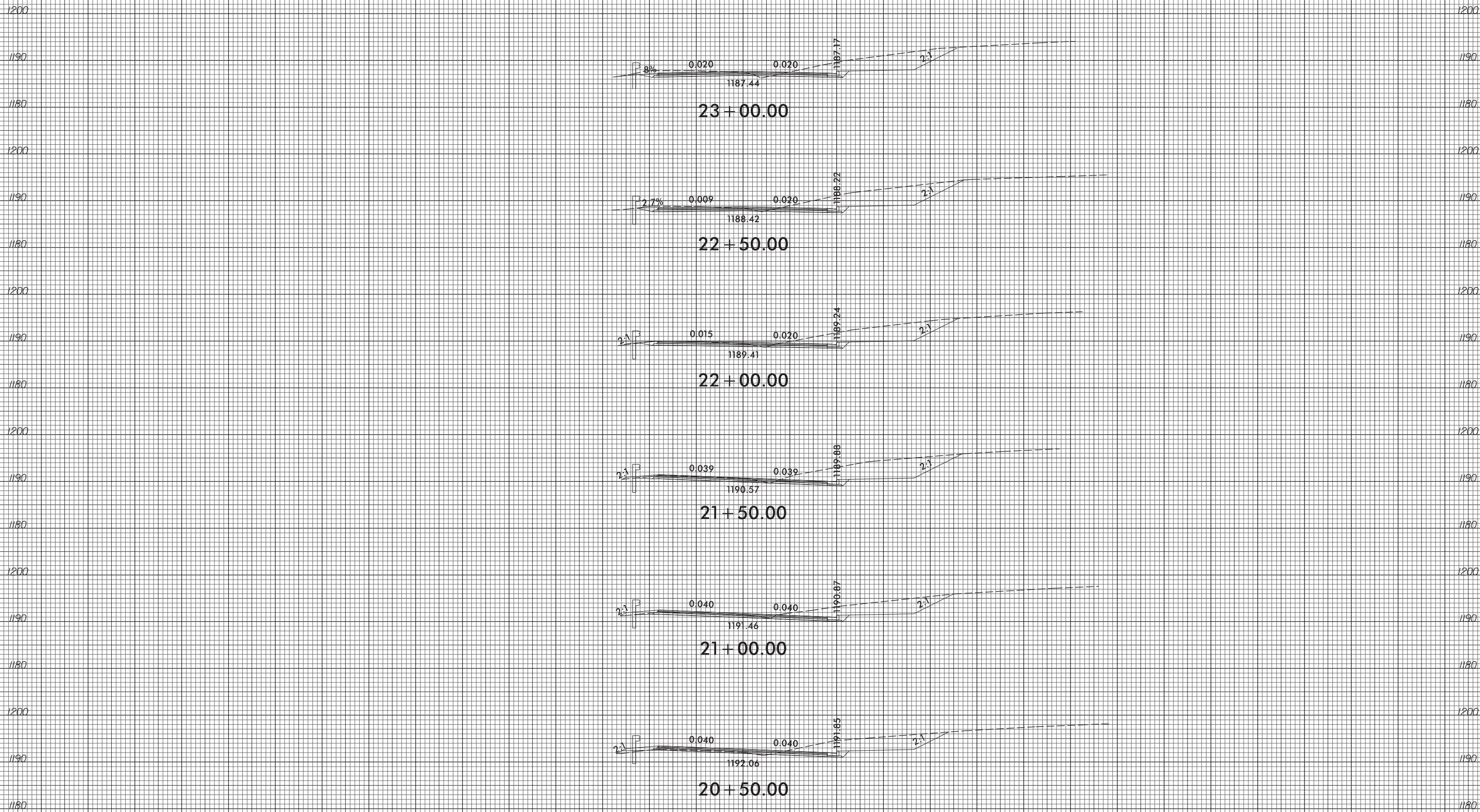

150 140 130 120 110 100 90 80 70 60 50 40 30 20 10 0 10 20 30 40 50 60 70 80 90 100 110 120 130 140 150

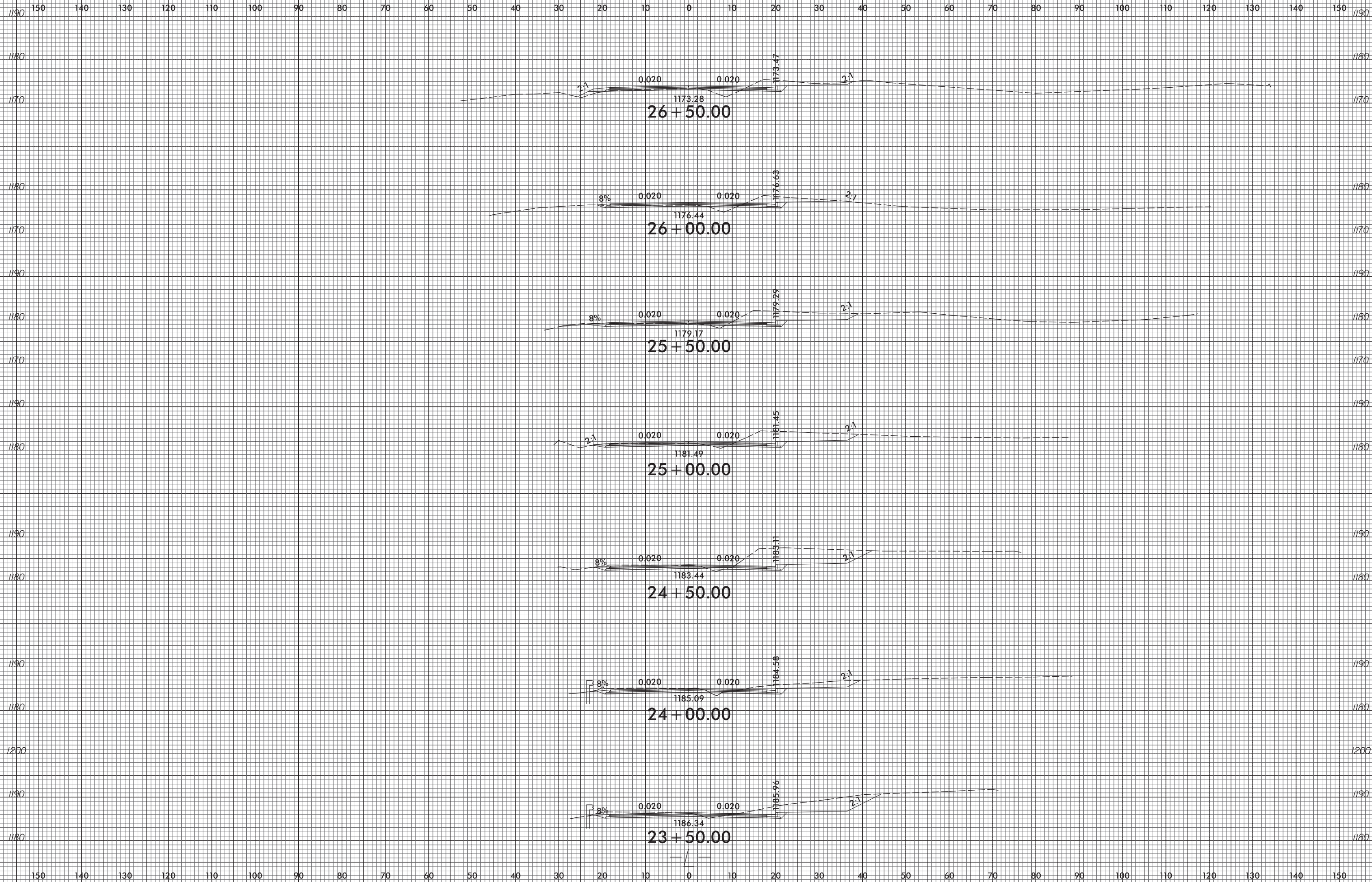

150 140 130 120 110 100 90 80 70 60 50 40 30 20 10 0 10 20 30 40 50 60 70 80 90 100 110 120 130 140 150

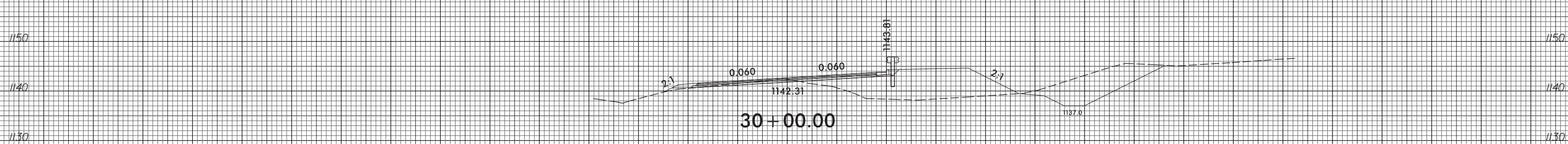
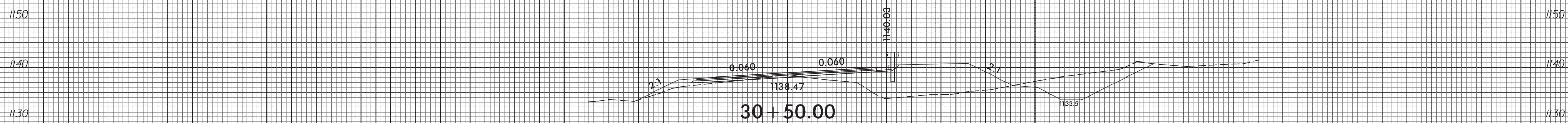
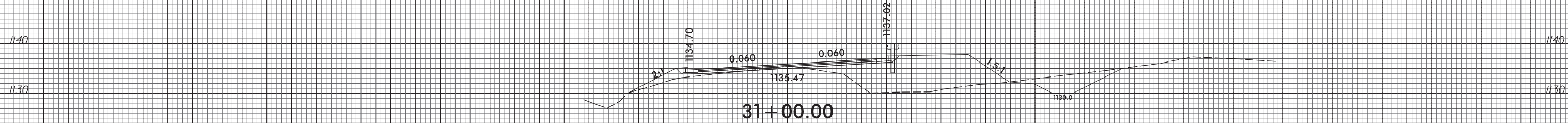
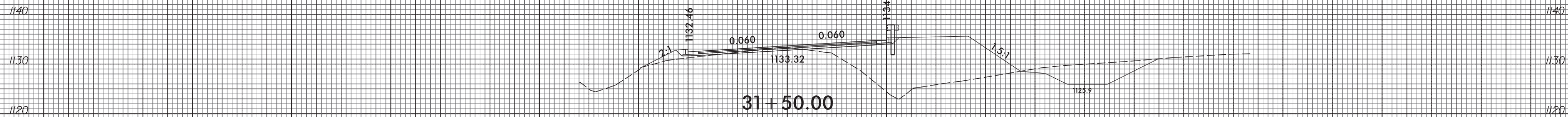
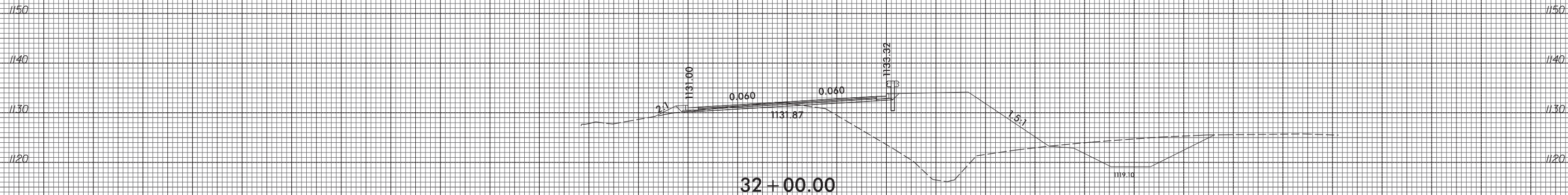

150 140 130 120 110 100 90 80 70 60 50 40 30 20 10 0 10 20 30 40 50 60 70 80 90 100 110 120 130 140 150

150 140 130 120 110 100 90 80 70 60 50 40 30 20 10 0 10 20 30 40 50 60 70 80 90 100 110 120 130 140 150

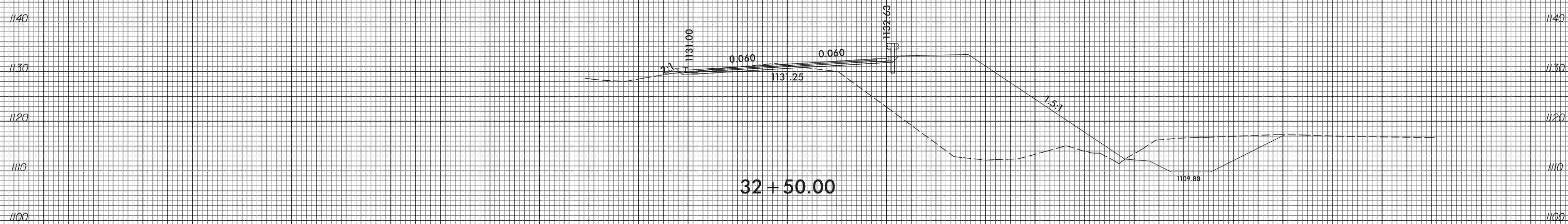
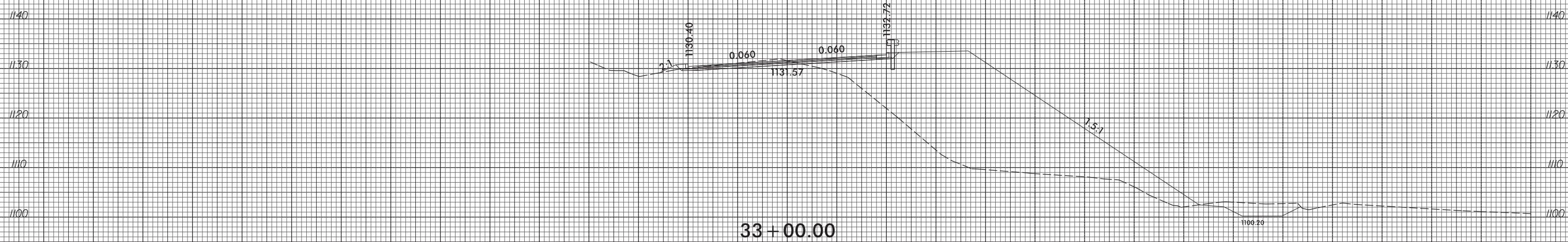
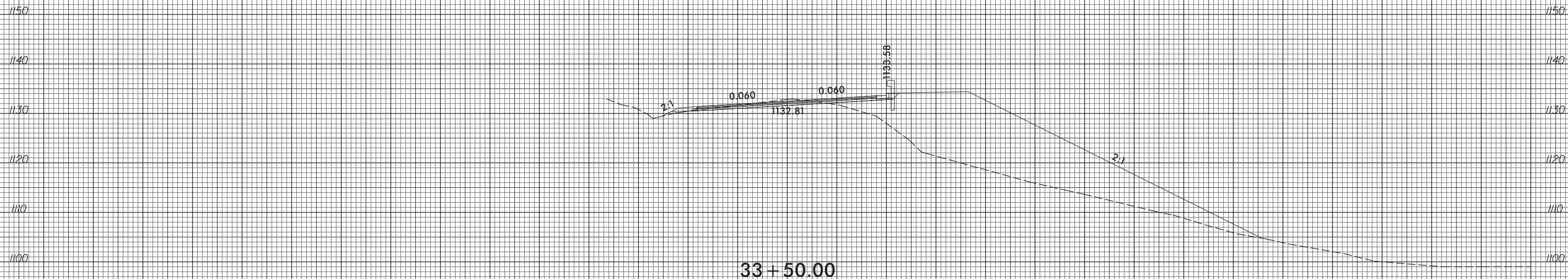

150 140 130 120 110 100 90 80 70 60 50 40 30 20 10 0 10 20 30 40 50 60 70 80 90 100 110 120 130 140 150

150 140 130 120 110 100 90 80 70 60 50 40 30 20 10 0 10 20 30 40 50 60 70 80 90 100 110 120 130 140 150

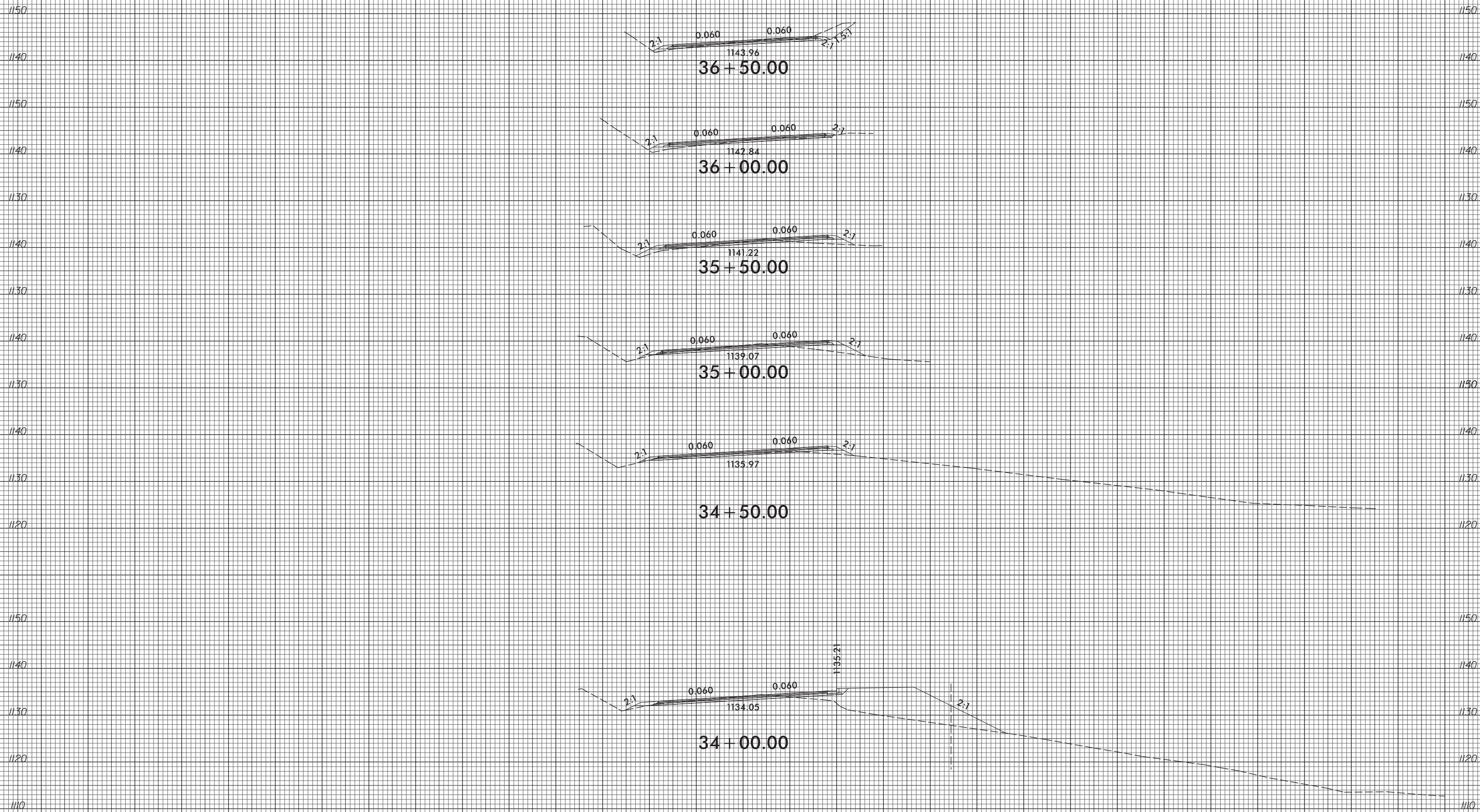

150 140 130 120 110 100 90 80 70 60 50 40 30 20 10 0 10 20 30 40 50 60 70 80 90 100 110 120 130 140 150

150 140 130 120 110 100 90 80 70 60 50 40 30 20 10 0 10 20 30 40 50 60 70 80 90 100 110 120 130 140 150

1140

1140

1130

1130

1120

1120

1140

1140

1130

1130

1150

1150

1140

1140

1130

1130

1150

1150

1140

1140

1150

1150

1140

1140

1130

1130

1140

1140

1130.72
39 + 50.00
END TIP PROJECT R-5967
-L- STA. 39 + 10.00

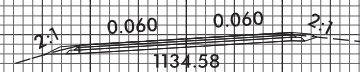

39 + 00.00

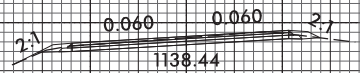

38 + 50.00

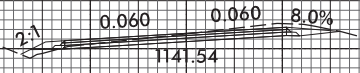

38 + 00.00

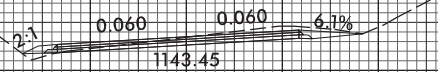

37 + 50.00

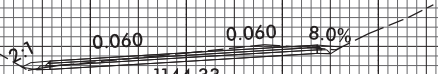

37 + 00.00



150 140 130 120 110 100 90 80 70 60 50 40 30 20 10 0 10 20 30 40 50 60 70 80 90 100 110 120 130 140 150

6/23/16



PROJ. REFERENCE NO.	R-5967
---------------------	--------

SHEET NO.	X-12
-----------	------

75 70 65 60 55 50 45 40 35 30 25 20 15 10 5 0 5 10 15 20 25 30 35 40 45 50 55 60 65 70 75

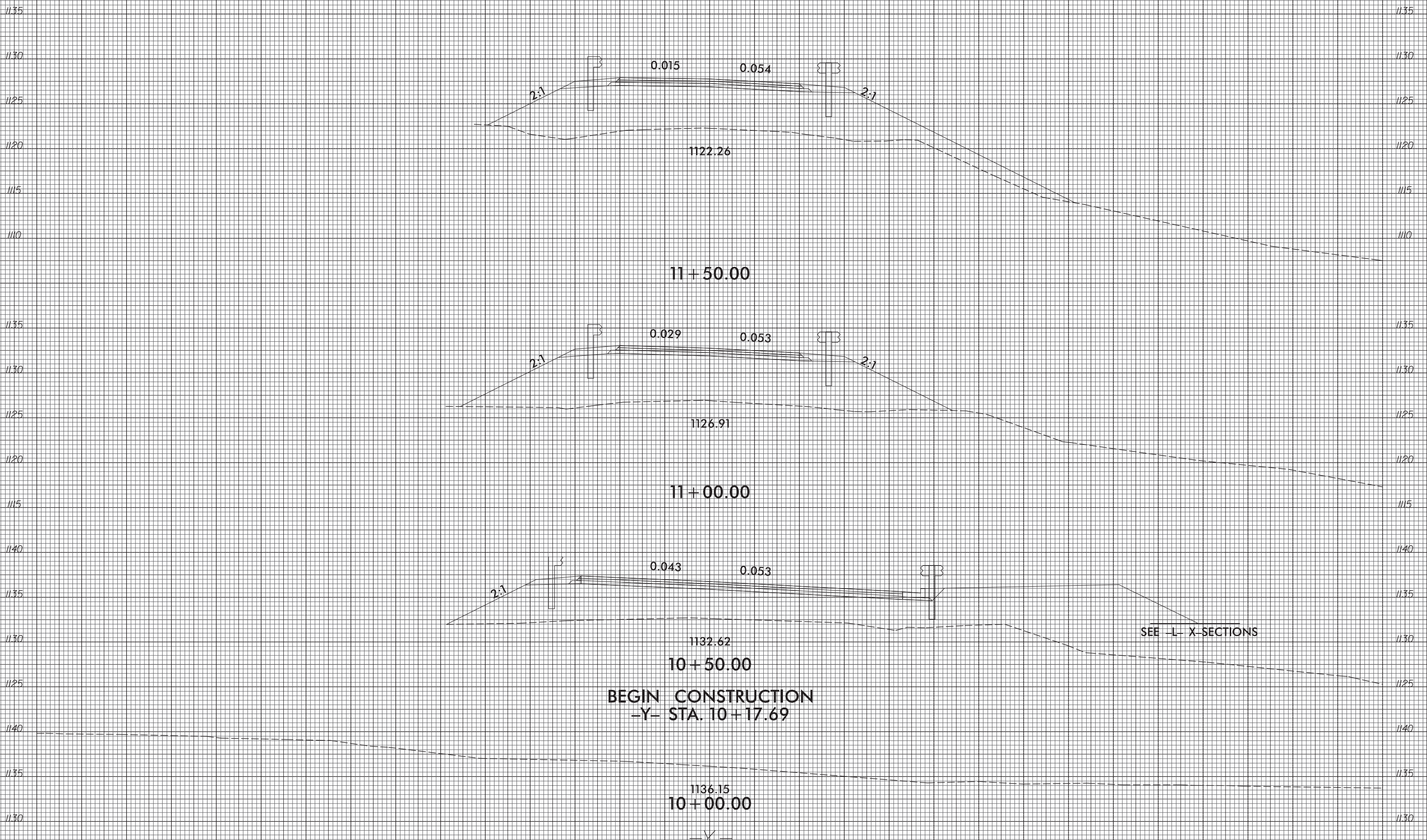

BEGIN CONSTRUCTION
 -Y- STA. 10+17.69

10-JAN-2022 11:51
 3330US-ENR\Burburke\Roadway\R-5967\Roadway\CorridorModeling\R5967_ddc_xpl_Y.dgn

75 70 65 60 55 50 45 40 35 30 25 20 15 10 5 0 5 10 15 20 25 30 35 40 45 50 55 60 65 70 75



75 70 65 60 55 50 45 40 35 30 25 20 15 10 5 0 5 10 15 20 25 30 35 40 45 50 55 60 65 70 75

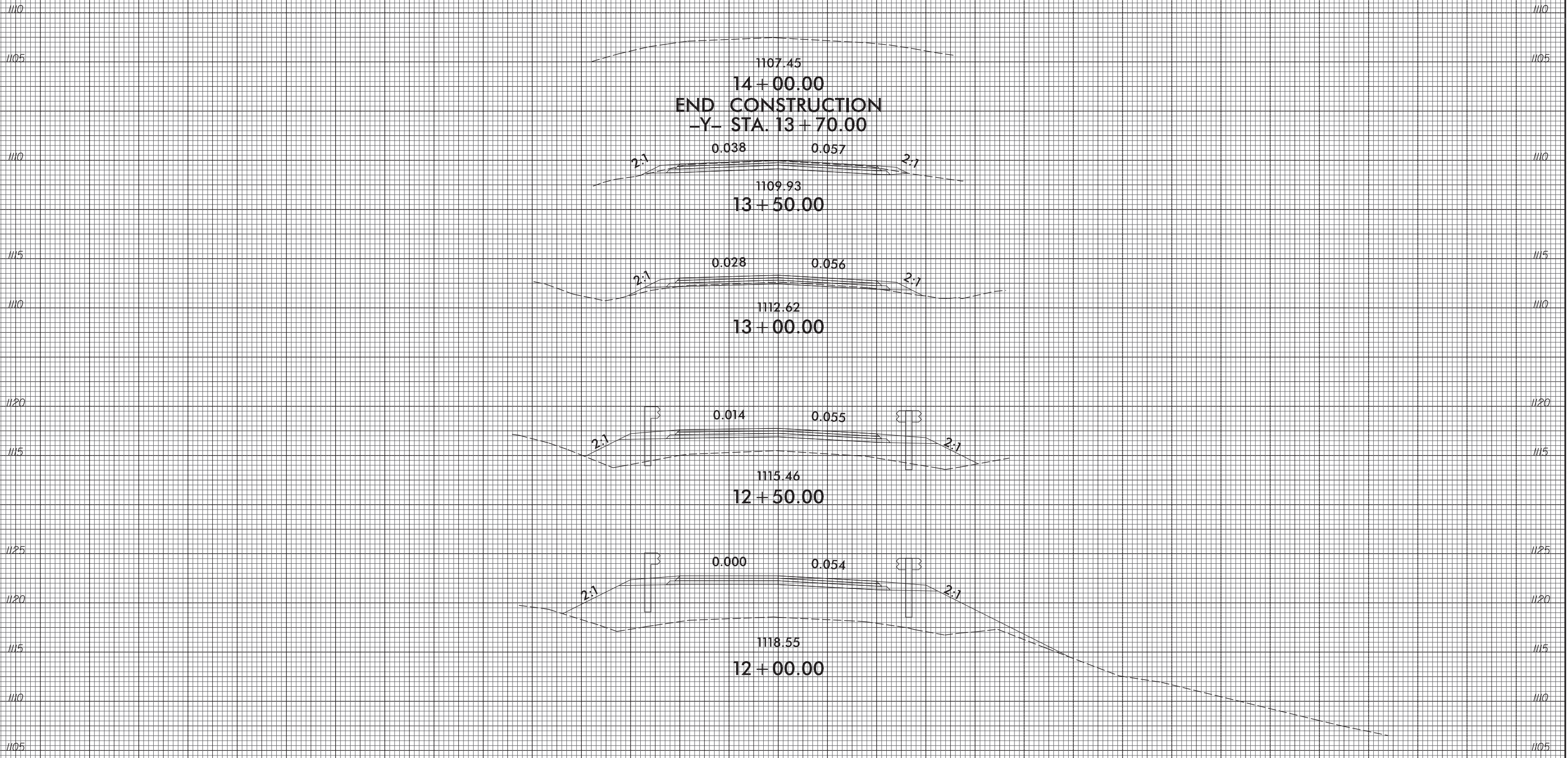

75 70 65 60 55 50 45 40 35 30 25 20 15 10 5 0 5 10 15 20 25 30 35 40 45 50 55 60 65 70 75

75 70 65 60 55 50 45 40 35 30 25 20 15 10 5 0 5 10 15 20 25 30 35 40 45 50 55 60 65 70 75

END CONSTRUCTION
-DRI- STA. 11+11.11

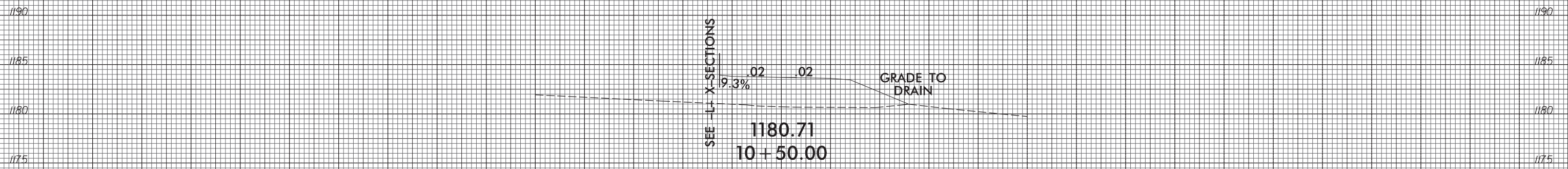
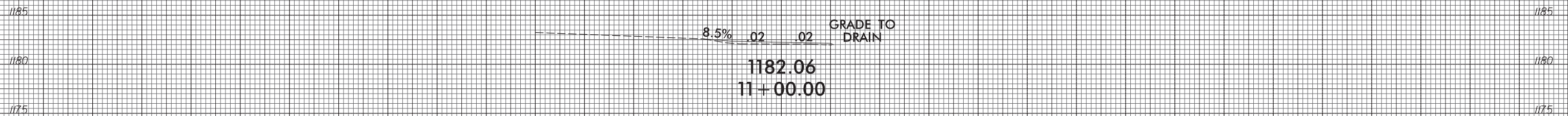
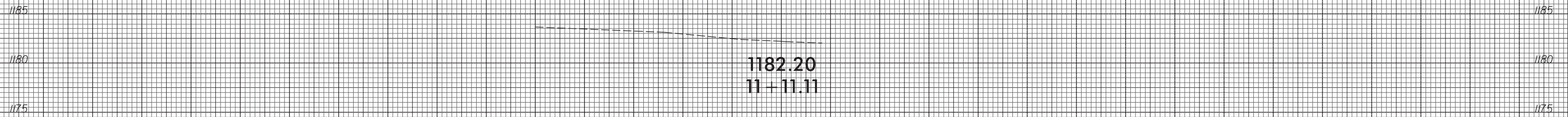

BEGIN CONSTRUCTION
-DRI- STA. 10+18.00

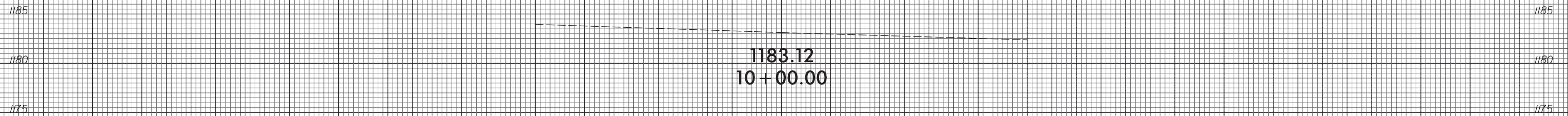

75 70 65 60 55 50 45 40 35 30 25 20 15 10 5 0 5 10 15 20 25 30 35 40 45 50 55 60 65 70 75

6/23/16



PROJ. REFERENCE NO.
R-5967

SHEET NO.
X-17

75 70 65 60 55 50 45 40 35 30 25 20 15 10 5 0 5 10 15 20 25 30 35 40 45 50 55 60 65 70 75

END CONSTRUCTION
-DR4- STA. 11+02.39

.02 .01
1188.45
11+00.00

2:1 2:1 .02 .02 2:1 2:1
1187.61
10+50.00

BEGIN CONSTRUCTION
-DR4- STA. 10+18.00

1184.72
10+00.00
-DR4-

10-JAN-2022 12:45
3:00 PM
S:\SUBSTRACTION\Burke\Roadway\Proj\R-5967.ddc.xml_DR4.dgn

75 70 65 60 55 50 45 40 35 30 25 20 15 10 5 0 5 10 15 20 25 30 35 40 45 50 55 60 65 70 75